

mitsubishi

A-A1S Module Conversion Adapter

User's Manual

**A1ADP-XY
A1ADP-SP**

Thank you for buying the Mitsubishi general-purpose programmable controller MELSEC-A Series

Prior to use, please read both this manual and detailed manual thoroughly and familiarize yourself with the product.



MODEL	A1ADP-U-JE
MODEL CODE	13JQ00
IB(NA)-0800352-I(1210)MEE	

● SAFETY PRECAUTIONS ●

(Read these precautions before using this product.)

Before using this product, please read this manual and the relevant manuals carefully and pay full attention to safety to handle the product correctly.

In this manual, the safety precautions are classified into two levels:
"⚠ WARNING" and "⚠ CAUTION".



Indicates that incorrect handling may cause hazardous conditions, resulting in death or severe injury.



Indicates that incorrect handling may cause hazardous conditions, resulting in minor or moderate injury or property damage.

Under some circumstances, failure to observe the precautions given under "⚠ CAUTION" may lead to serious consequences.

Observe the precautions of both levels because they are important for personal and system safety.

Make sure that the end users read this manual and then keep the manual in a safe place for future reference.

[DESIGN PRECAUTIONS]

⚠ WARNING

- When using the A series module to which the A-A1S module conversion adapter has been installed on the right side, attach a dustproof cover to the module.
If no dustproof cover is attached, foreign matter will enter the module, resulting in a failure. Furthermore, internal parts of the module may be fried in the short circuit test or when an overcurrent or overvoltage is accidentally applied to the external I/O section.
- Before installing the AnS series module to the A1ADP, attach the dustproof cover to the module.
If no dustproof cover is attached, foreign matter will enter the module, resulting in a failure. Furthermore, internal parts of the module may be fried in the short circuit test or when an overcurrent or overvoltage is accidentally applied to the external I/O section.

[INSTALLATION PRECAUTIONS]

CAUTION

- Use the programmable controller in the environment given in the general specifications section of the User's manual for CPU module being used. Using the programmable controller outside the range of the general specifications may result in electric shock, fire or erroneous operation or may damage or degrade the product.
- Fully insert adapter fixing projections on the lower part of an adapter into fixing holes on the base unit, then tighten the adapter mounting screw within the specified torque.
If the adapter is not correctly installed or no screw is tightened, it causes malfunctions, a failure, or drop.
Tightening the screw excessively may damage the screw and/or adapter, resulting in a drop of the adapter and installed module, short circuit, or malfunctions.
- Be sure to shut off all phases of the external supply power used by the system before installing or removing the adapter.
Failure to do so may damage the products.
- Do not directly touch the conductive part or electronic components of an adapter.
Doing so may cause malfunctions or a failure of the adapter.

[WIRING PRECAUTIONS]

WARNING

- Be sure to shut off all phases of the external supply power used by the system before wiring.
Failure to do so may result in an electric shock or damage of the product.
- Before energizing and operating the system after wiring, be sure to attach the terminal cover supplied with the product.
Failure to do so may cause an electric shock.

CAUTION

- Wire the module correctly after confirming the rated voltage and terminal layout.
Connecting a power supply of a different voltage rating or incorrect wiring may cause a fire or failure.
- Do not connect multiple power supply modules to one module in parallel.
The power supply modules may be heated, resulting in a fire or failure.
- Press, crimp or properly solder the connector for external connection with the specified tool.
Incomplete connection may cause a short circuit, fire or malfunctions.

[WIRING PRECAUTIONS]

CAUTION

- Tighten terminal screws within the specified torque range. If the screw is too loose, it may cause a short circuit, fire or malfunctions.
If too tight, it may damage the screw and/or the module, resulting in a short circuit or malfunctions.
- Carefully prevent foreign matter such as dust or wire chips from entering the module.
Failure to do so may cause a fire, failure or malfunctions.

[STARTING AND MAINTENANCE PRECAUTIONS]

WARNING

- Be sure to shut off all phases of the external supply power used by the system before cleaning or retightening the terminal screws, module mounting screw, or adapter mounting screw.
Failure to do so may result in an electric shock.
If they are too loose, it may cause a short circuit or malfunctions.
If too tight, it may cause damage to the screws and/or module, resulting in a drop of the adapter and installed module, short circuit, or malfunctions.

CAUTION

- Do not disassemble or modify each of adapters.
Doing so may cause a failure, malfunctions, personal injuries, and/or a fire.
- When using a wireless communication device such as a mobile phone, keep a distance of 25cm (9.84inch) or more from the programmable controller in all directions.
Failure to do so may cause malfunctions.
- Be sure to shut off all phases of the external supply power used by the system before installing or removing the adapter.
Failure to do so may result in a failure or malfunctions of the adapter and installed module.
- Before handling adapters, touch a conducting object such as a grounded metal to discharge the static electricity from the human body.
Failure to do so may cause a failure or malfunctions of the installed module.

[DISPOSAL PRECAUTIONS]

CAUTION

- When disposing of this product, treat it as industrial waste.

● CONDITIONS OF USE FOR THE PRODUCT ●

- (1) Mitsubishi programmable controller ("the PRODUCT") shall be used in conditions;
- where any problem, fault or failure occurring in the PRODUCT, if any, shall not lead to any major or serious accident; and
 - where the backup and fail-safe function are systematically or automatically provided outside of the PRODUCT for the case of any problem, fault or failure occurring in the PRODUCT.
- (2) The PRODUCT has been designed and manufactured for the purpose of being used in general industries.
MITSUBISHI SHALL HAVE NO RESPONSIBILITY OR LIABILITY (INCLUDING, BUT NOT LIMITED TO ANY AND ALL RESPONSIBILITY OR LIABILITY BASED ON CONTRACT, WARRANTY, TORT, PRODUCT LIABILITY) FOR ANY INJURY OR DEATH TO PERSONS OR LOSS OR DAMAGE TO PROPERTY CAUSED BY the PRODUCT THAT ARE OPERATED OR USED IN APPLICATION NOT INTENDED OR EXCLUDED BY INSTRUCTIONS, PRECAUTIONS, OR WARNING CONTAINED IN MITSUBISHI'S USER, INSTRUCTION AND/OR SAFETY MANUALS, TECHNICAL BULLETINS AND GUIDELINES FOR the PRODUCT.
("Prohibited Application")
Prohibited Applications include, but not limited to, the use of the PRODUCT in;
- Nuclear Power Plants and any other power plants operated by Power companies, and/or any other cases in which the public could be affected if any problem or fault occurs in the PRODUCT.
 - Railway companies or Public service purposes, and/or any other cases in which establishment of a special quality assurance system is required by the Purchaser or End User.
 - Aircraft or Aerospace, Medical applications, Train equipment, transport equipment such as Elevator and Escalator, Incineration and Fuel devices, Vehicles, Manned transportation, Equipment for Recreation and Amusement, and Safety devices, handling of Nuclear or Hazardous Materials or Chemicals, Mining and Drilling, and/or other applications where there is a significant risk of injury to the public or property.

Notwithstanding the above, restrictions Mitsubishi may in its sole discretion, authorize use of the PRODUCT in one or more of the Prohibited Applications, provided that the usage of the PRODUCT is limited only for the specific applications agreed to by Mitsubishi and provided further that no special quality assurance or fail-safe, redundant or other safety features which exceed the general specifications of the PRODUCTS are required. For details, please contact the Mitsubishi representative in your region.

REVISIONS

* The manual number is noted at the lower right of the top cover.

Print Date	*Manual Number	Revision
Jun., 2006	IB(NA)-0800352-A	First printing
May, 2007	IB(NA)-0800352-B	Correction Section 2.3, Chapter 7, Section 8.2
Oct., 2007	IB(NA)-0800352-C	Correction Chapter 7, Section 8.2
Jul., 2008	IB(NA)-0800352-D	Correction Chapter 7
Nov., 2008	IB(NA)-0800352-E	Correction Section 2.1, 2.2, 8.2
Feb., 2009	IB(NA)-0800352-F	Correction Section 1.1, 1.3, 2.1.3, 2.3, Chapter 7, Section 8.1, 8.2 Addition Section 2.1.4
Sep., 2009	IB(NA)-0800352-G	Correction Chapter 7
Dec., 2011	IB(NA)-0800352-H	Correction COMPLIANCE WITH EMC AND LOW VOLTAGE DIRECTIVES Addition SAFETY PRECAUTIONS(Chinese), CONDITIONS OF USE FOR THE PRODUCT
Oct., 2012	IB(NA)-0800352-I	Correction SAFETY PRECAUTIONS, Chapter 2, 7, Section 8.2, 8.3, 8.4

This manual confers no industrial property rights or any rights of any other kind, nor does it confer any patent licenses. Mitsubishi electric Corporation cannot be held responsible for any problems involving industrial property rights which may occur as a result of using the contents noted in this manual.

CONTENTS

1. OVERVIEW.....	1
1.1 Overview.....	1
1.2 Supplied Parts	2
1.3 Related Parts (Sold Separately).....	2
2. SYSTEM CONFIGURATION	3
2.1 For installing the A1ADP to an A/QnA (large type) series main base unit or extension base unit	3
2.1.1 System Configuration	3
2.1.2 Available Base Units List.....	4
2.1.3 Available CPU modules list	4
2.1.4 List of available remote I/O stations	5
2.2 For installing the A1ADP to the A series extension base unit connected to a Q series base unit	5
2.2.1 System Configuration	5
2.2.2 Available Base Units List.....	6
2.2.3 Available CPU modules list	6
2.3 Precautions for Use	6
3. SPECIFICATIONS	9
3.1 Performance Specifications.....	9
4. PARTS NAMES	10
5. LOADING AND INSTALLATION.....	11
5.1 Precautions when Handling.....	11
5.2 Installation/Removal Procedures of the A1ADP + AnS Series Module	11
5.2.1 Installing/removing the A1ADP	12
5.2.2 Installing/removing the dustproof cover	14
5.2.3 Installing/removing the AnS series module	16
6. EXTERNAL DIMENSIONS	18
7. COMPATIBLE MODELS LIST	19
8. REPLACEABLE MODULES LIST.....	23
8.1 How to See the List	23
8.2 List of Transition from the A Series to AnS Series	25
8.3 List of Transition from the QnA Series to AnS Series.....	63
8.4 List of Transition from the Q4AR Series to AnS Series	64

GENERIC TERMS AND ABBREVIATIONS

Unless otherwise specified, this manual uses the following generic terms and abbreviations to explain the A-A1S module conversion adapter.

Generic term/abbreviation	Description
A1ADP-XY	Abbreviation for the A-A1S module conversion adapter of the A1ADP-XY type.
A1ADP-SP	Abbreviation for the A-A1S module conversion adapter of the A1ADP-SP type.
A1ADP	Generic term for the A1ADP-XY and A1ADP-SP.
A1ADP + AnS series module	Abbreviation when the AnS series I/O module or special function module is installed to the A1ADP.

COMPLIANCE WITH EMC AND LOW VOLTAGE DIRECTIVES

(1) Method of ensuring compliance

To ensure that Mitsubishi programmable controllers maintain EMC and Low Voltage Directives when incorporated into other machinery or equipment, certain measures may be necessary. Please refer to one of the following manuals.

- User's manual for the CPU module used
- User's manual (hardware) for the CPU module or base unit used

(2) Additional measures

For the compliance of this product with the EMC and Low Voltage Directives, installing a noise filter (power supply line filter) as the following is required.

- (a) When using the A1ADP-XY with an AnS series output module, attach any of the following noise filters (power supply line filters) to reduce conductive noise of 24VDC external supply power cable.

Noise filter model name	ZHC2203-11	ZHC2206-11	ZHC2210-11	MBS4830
Manufacturer	TDK			DENSEI-LAMBDA
Rated current	3A	6A	10A	30A
Rated voltage	250V			48V

- (b) Referring to the following, attach a noise filter (power supply line filter) to the 24VDC external supply power cable connected to the AnS series output module.

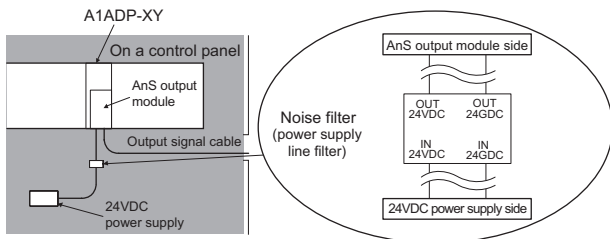

- (c) The following describes the precautions for attaching a noise filter.

- 1) Do not bundle the wires on the input side and output side of the noise filter.

When bundled, the input side noise will be induced into the output side wires from which the noise was filtered.

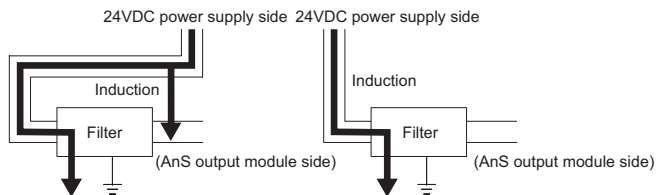

- 1) The noise will be included when the input and output wires are bundled. 2) Separate and lay the input and output wires.

- 2) Earth the noise filter earthing terminal to the control cabinet with the shortest wire possible (approx. 10cm (3.94 in.)).

1. OVERVIEW

1.1 Overview

This manual describes specifications, system equipment, part names, loading, and installation of the A-A1S module conversion adapters of the A1ADP-XY type and A1ADP-SP type.

The A1ADP is an adapter module used to install the AnS series I/O modules and special function modules to the base unit for A/QnA (large type) series.

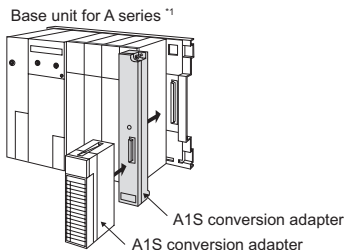

*1 For details of the system configuration that enables the installing the A1ADP to A series base units, refer to Chapter 2.

A1ADP-XY.....For the AnS series I/O modules

A1ADP-SP.....For the AnS series special function modules

POINT

When modules are installed in either of the following combinations, the operation is not guaranteed.

- Combination of the A1ADP-XY with the AnS series special function modules
- Combination of the A1ADP-SP with the AnS series I/O modules

However, for the following models, the combination of the module type configured in the I/O assignment setting and the A1ADP model that can be combined differs. Pay attention when selecting the A1ADP.

Model	Type	Usable A1ADP model
A1SI61	Special module	A1ADP-XY
A1SJ51T64	Output module	A1ADP-SP
A1SS91	Output module	A1ADP-SP

1.2 Supplied Parts

The parts enclosed with the A1ADP are listed below.

Product	Type	Quantity	Remarks
A-A1S module conversion adapter	A1ADP-XY or A1ADP-SP	1	-
The dustproof cover for the A1ADP-XY/SP	-	1	"A1ADP" is shown on the backside of the dustproof cover.
This manual	-	1	-

For references of the dustproof cover, see the back cover of this manual.

1.3 Related Parts (Sold Separately)

When the A (large type) module has been installed on the right of a slot to which the A1ADP has been loaded, attach the following dustproof cover to the A (large type) series module side.

The following dustproof cover is not an accessory. Please purchase it separately.

Product name	Manufacturer	Quantity	Remarks
A55B, 58B I/O dustproof cover	Mitsubishi Electric System Service Co., Ltd.	1	Same dustproof cover included in the A52B, A55B, and A58B.

For references of the dustproof cover, see the back cover of this manual.

2. SYSTEM CONFIGURATION

The A1ADP can be installed to the following base units.

- A/QnA (large type) series main base units or extension base units
- A series extension base units installed to Q series base units

This section describes the system configuration, available base units, available CPU modules, and precautions for the A1ADP.

2.1 For installing the A1ADP to an A/QnA (large type) series main base unit or extension base unit

2.1.1 System Configuration

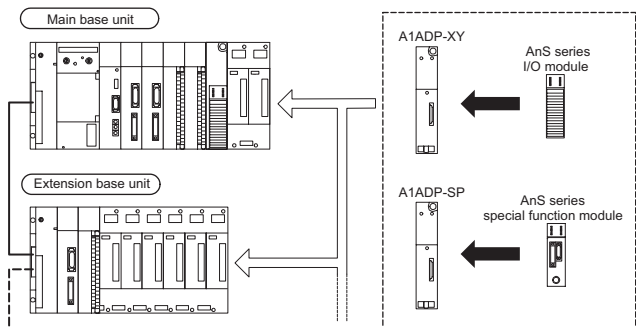

2.1.2 Available Base Units List

The following table shows the base units to which the A1ADP can be installed.

Up to three A1ADPs can be installed to one base unit.

Main base unit		Extension base unit	
Type	Number of installable adapters	Type	Number of installable adapters
A38B	3	A68B	3
A38B-E	3	A68B-UL	3
A38B-UL	3	A65B	3
A38HB	3	A65B-UL	3
A38HBEU	3	A62B	2
A35B	3	A58B	3
A35B-E	3	A58B-UL	3
A35B-UL	3	A55B	3
A32B	2	A55B-UL	3
A32B-E	2	A52B	2
A32B-UL	2	A68RB	3
A32B-S1	2		
A37RHB	3		
A33RB	2		
A32RB	1		

2.1.3 Available CPU modules list

The following table shows the CPU modules available for the A1ADP use.

Available CPU module ^{*1}			
A1NCPUP21	A1NCPUR21	A2NCPUP21	A2NCPUR21
A2NCPUP21	A2NCPUR21	A2NCPUP21-S1	A2NCPUR21-S1
A2NCPUP21-S1	A3NCPUP21	A3NCPUP21	A3NCPUR21
A2ACPU	A2ACPUP21	A2ACPUP21	A2ACPUR21
A2ACPUP21-S1	A2ACPUR21-S1	A3ACPU	A3ACPUP21
A3ACPUP21	A2UCPU	A2UCPU-S1	A3UCPU
A4UCPU	A1NCPUP21-S3	A2NCPUP21-S3	A2NCPUP21-S4
A3NCPUP21-S3	A2ACPUP21-S3	A2ACPUP21-S4	A3ACPUP21-S3
Q2ACPU	Q2ACPU-S1	Q3ACPU	Q4ACPU
Q4ARCPU			

*1 The relevant modules are the CPU modules that had been discontinued at the end of September, 2006 (at the end of September, 2008 for the models that were kept produced for more 2 years as a spare part).

The CPU modules that were discontinued before the end of September, 2006 and not mentioned in the above table (such as the AnCPU and A3HCPU) are unavailable.

2.1.4 List of available remote I/O stations

The following table shows the link modules for MELSECNET and MELSECNET/10 remote I/O station for which the A1ADP can be used.

Available modules ^{*1}			
AJ72P25	AJ72P25-S3	AJ72R25	AJ72T25B
AJ72LP25	AJ72LP25G	AJ72LR25	AJ72BR15
AJ72QLP25	AJ72QLP25G	AJ72QLR25	AJ72QBR15

*1 There are restrictions on the available modules. For details, refer to the following manuals.

- Type MELSECNET, MELSECNET/B Data Link System Reference Manual
- Type MELSECNET/10 Network System (Remote I/O network) Reference Manual
- For QnA/Q4AR MELSECNET/10 Network System Reference Manual
- User's manual for the relevant module

2.2 For installing the A1ADP to the A series extension base unit connected to a Q series base unit

2.2.1 System Configuration

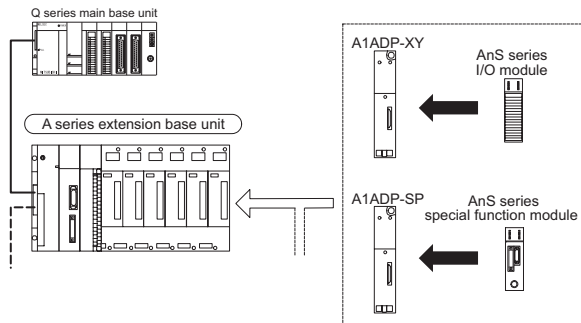

2.2.2 Available Base Units List

The following table shows the base units to which the A1ADP can be installed.

Up to three A1ADPs can be installed to one base unit.

Extension base unit		Remarks
Type	Number of installable adapters	
A68B	3	Install the QA6ADP to an extension main base unit. However, the modules that can be installed to have restrictions. For details, refer to the QA6ADP QA Conversion Adapter Module User's Manual.
A68B-UL	3	
A65B	3	
A65B-UL	3	
A62B	2	
A58B	3	
A58B-UL	3	
A55B	3	
A55B-UL	3	
A52B	2	
QA68B	3	The modules that can be installed to have restrictions. For details, refer to the QA65B/QA68B Extension Base Unit User's Manual.
QA65B	3	

2.2.3 Available CPU modules list

The following table shows the CPU modules available for the A1ADP use.

Available CPU module				
Q02CPU	Q02HCPU	Q06HCPU	Q12HCPU	Q25HCPU

2.3 Precautions for Use

- (1) When replacing the A (large type) series module by the A1ADP + AnS series module, the internal current consumption may increase. At replacement, make sure to check the 5VDC internal current consumption of the modules before and after replacement. If the 5VDC internal current consumption increases after the replacement, confirm that the current consumption of the modules used does not exceed the rated output current of the power supply module used.

- (2) When the A1ADP + AnS series module is installed to an extension base unit not needing a power supply module (A52B, A55B, or A58B) in the case that the increase in 5VDC internal current consumption may cause, voltage drop increases in the extension cable. Therefore, recalculating the receiving end voltage is required.

(For confirmation method, refer to the "Application standards of Extension Base Units" (A52B, A55B, or A58B) in the CPU module's User's Manual.)

- (3) The A (large type) series module differs from the A1ADP+AnS series module in specifications. For the equivalent products and specifications comparison, refer to Chapter 8 and the Transition from MELSEC-A/QnA Large Type Series to AnS/Q2AS Small Type Series Handbook (L(NA)08064ENG).
- (4) AnS series 32-point I/O modules and special function modules are connector type. Accordingly, when installing them to an A series base unit using the A1ADP, its depth is deeper than when installing an A series 32-point module.

When using the AnS series 32-point I/O modules or special function modules, confirm that there is enough room.

Example When replacing the A series 32-point module

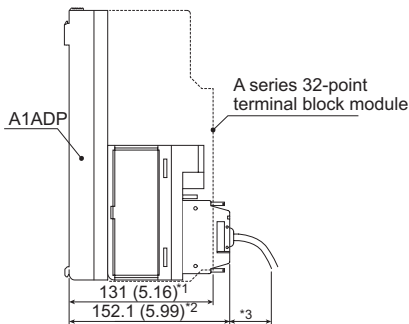

Unit: mm (inch)

- *1 Depth dimension of the A series 32-point terminal block module
 *2 Depth dimension of the A1ADP + AnS series 32-point connector type module
 *3 Consider the bending radius of a connector cable.

- (5) The AnS series output module with a fuse detects fuse blown if external supply power has not been input.
Use special relay M9084 or SM1084 (error check) at power-on with the external supply power OFF so that fuse blown may not be detected.
- (6) When mounting the A1ADP-XY+AnS series output module with a fuse on the MELSECNET/II remote I/O station (AJ72P25 or AJ72R25), the CPU module of the master station may detect "UNIT VERIFY ERR."
However, note that the AJ72P25 or AJ72R25 whose software version is "P" or later is used, "UNIT VEFIRY ERR." will not be detected.
Turning ON the power supply of the master station after turning ON the power supply of the remote I/O station and the 24VDC external power supply enables to avoid "UNIT VEFIRY ERR."
Also, if the fuse blown is detected, cancel the error by the reset operation of the CPU module used.

3. SPECIFICATIONS

3.1 Performance Specifications

The performance specifications of the A1ADP are shown below.

Specification	A1ADP-XY	A1ADP-SP
5VDC internal current consumption	3.4mA	0mA
External dimensions	250(H)×37.5(W)×35.5(D) (9.84×1.48×1.40) mm (inch)	
Weight	0.20kg	

4. PARTS NAMES

Each part name of the A1ADP is shown in the table below.

No.	Name	Usage
1)	Adapter mounting screw	A screw for installing the A1ADP to a base unit (Make sure to tighten the screw).
2)	Module mounting screw hole	A screw hole for fixing the A1ADP to AnS series module (for M4 screw) (Make sure to tighten the screw).
3)	Module connector	A connector for connecting the A1ADP to AnS series module.
4)	Projection mounting hole for fixing A1S module	A hole for attaching the module fixing projection on AnS series module.
5)	Adapter fixing hook	A hook for fixing it to the module fixing hole on a base unit.
6)	Base connector	A connector for connecting the A1ADP to a base unit.
7)	Rating plate	A seal such as the product name is described.
8)	Adapter fixing projection	A projection for fixing it to the module fixing hole on a base unit.

5. LOADING AND INSTALLATION

5.1 Precautions when Handling

The following is an explanation of handling precautions of the A1ADP.

- (1) Since the adapter case is made of plastic, do not drop it or subject it to mechanical impact to it.
- (2) Execute tightening of installation screws within the range indicated below.

Screw location	Tightening torque range
Module installation screw of AnS series (M4 screw)	78 to 118N•cm
Adapter mounting screw (M4 screw)	78 to 118N•cm

- (3) To correctly install the adapter module to the base unit, insert the adapter fixing projections provided at the bottom of the module in the module mounting holes in the base unit. And then, secure the module by tightening the adapter mounting screw.
To remove the module, remove the adapter mounting screw first. And then, pull out the module so that the adapter fixing projections are removed from the holes in the base unit.

5.2 Installation/Removal Procedures of the A1ADP + AnS Series Module

This section describes the procedures for installing/removing the A1ADP to/from a base unit and AnS series module.

- (1) Installation procedure

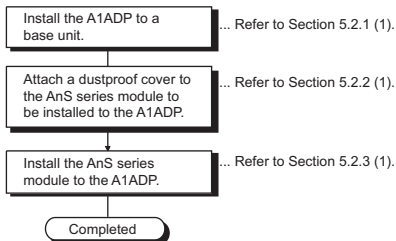

POINT

Note when installing the AnS series module before tightening an adapter mounting screw of the A1ADP, the tightening cannot be done.

(2) Removal procedure

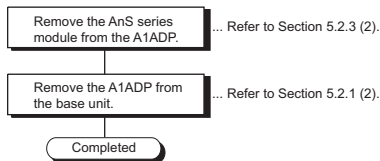

5.2.1 Installing/removing the A1ADP

(1) A1ADP installation

Insert the two adapter fixing projections into the module fixing hole (B) in the base unit.

Load the adapter into the baseunit by pushing it in the direction of arrow.

Tighten two adapter mounting screws after confirming that the hook on the A1ADP is fully inserted into the module fixing hole (A) on the base unit.

Completed

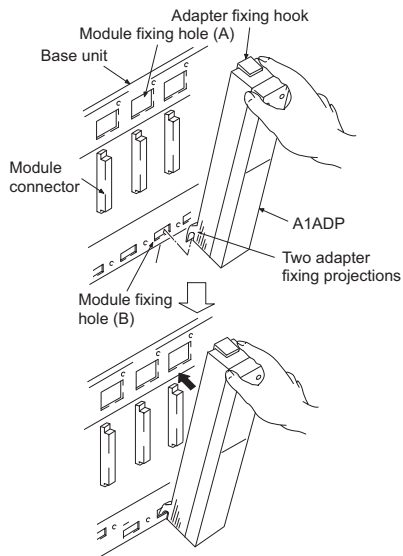
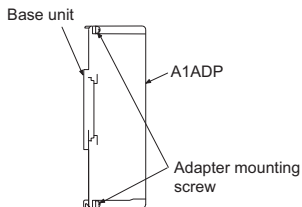

POINT

For fixing the A1ADP, insert the adapter fixing projections into the module fixing holes (B). Forceful installation may damage the module connector and/or A1ADP.

(2) A1ADP removal

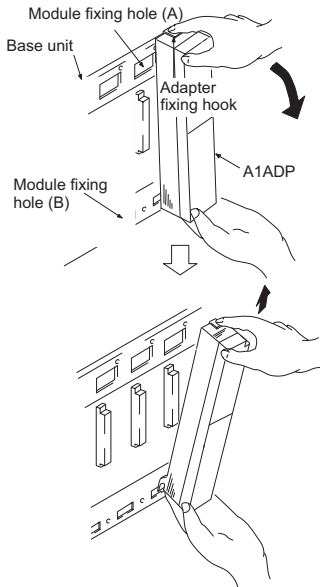
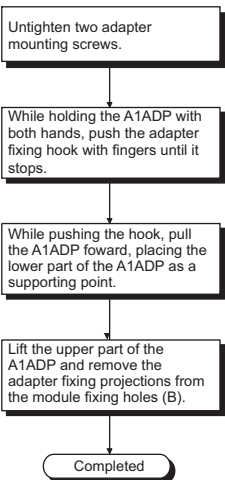

POINT

Before removing the A1ADP, make sure to untighten two adapter mounting screws. Then, remove the adapter fixing hook from a module fixing hole (A), and also the adapter fixing projections from a module fixing holes (B). Forcefully removing the adapter may damage the adapter fixing hook and/or the adapter fixing projections.

5.2.2 Installing/removing the dustproof cover

Before installing the AnS series module to the A1ADP, attach the dustproof cover for the A1ADP-XY/SP, included with the A1ADP, to the module.

If no dustproof cover is attached, foreign matter will enter the module, resulting in a failure. Furthermore, internal parts of the module may be fried in the short circuit test or when an overcurrent or overvoltage is accidentally applied to the external I/O section.

(1) Installation

To install the dustproof cover into the AnS series module, first insert the cover to the terminal side and then press the dustproof cover against the module as shown in the figure.

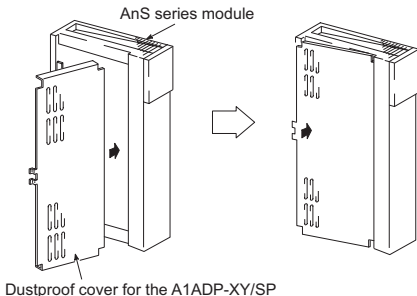

(2) Removal

To remove the dustproof cover from the I/O module, insert the tip of a flat-head screwdriver into the hole as shown in the figure, then pry the tab of the cover out from the hole using the screwdriver.

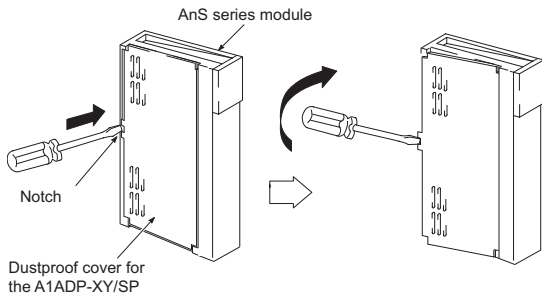

5.2.3 Installing/removing the AnS series module

(1) AnS series module installation

Insert the module fixing projection of the AnS series module into a projection mounting hole for fixing A1S module on the A1ADP.

Install the AnS series module to the A1ADP by pushing it in the direction of an arrow.

Tighten the module mounting screw after confirming that the module is securely installed to the A1ADP.

Completed

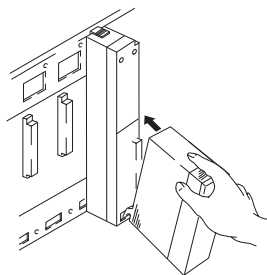
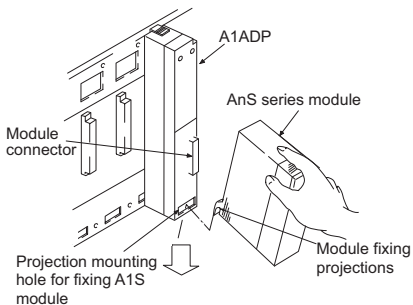
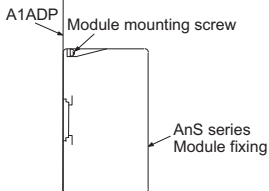

POINT

For fixing the AnS series module, insert the module fixing projection into the module fixing hole. Forceful installation may damage the module connector and/or A1ADP.

(2) AnS series module removal

Remove the module mounting screw.

Pull the upper AnS series module forward with placing its underneath as a fulcrum.

Lift upwards and remove the module hook from the module fixing hole.

Completed

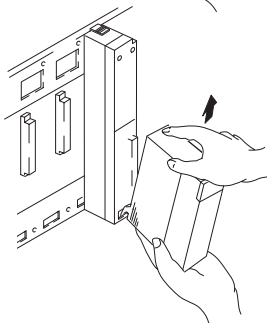
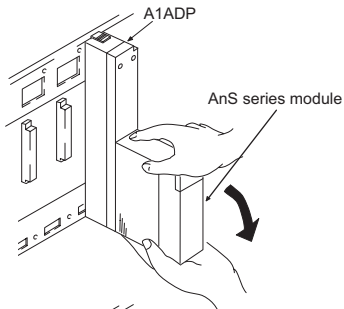

POINT

For removing the AnS series module, untighten the module mounting screw first and then remove the module fixing projection from the module fixing hole. Forceful installation may damage the module connector and/or A1ADP.

6. EXTERNAL DIMENSIONS

The external dimensions of the A1ADP are shown below.

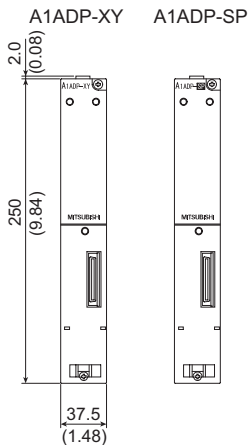

When a module is installed

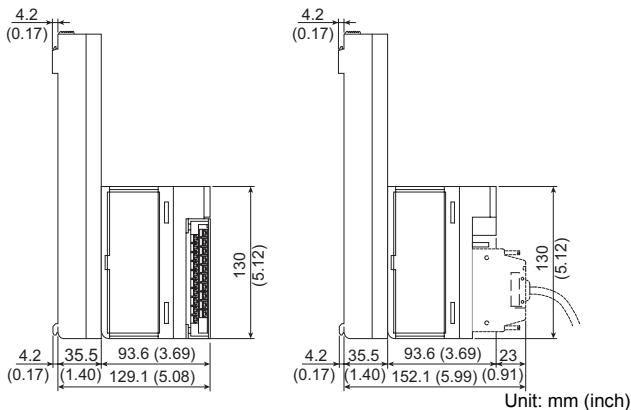

7. COMPATIBLE MODELS LIST

This section describes the AnS series modules that can be installed to the A1ADP.

Product	Model	Mounting of the A1ADP			Applicable adapter
		QCPU	QnACPU	ACPU	
Input module	A1SX10		○		XY
	A1SX10EU		○		XY
	A1SX20		○		XY
	A1SX20EU		○		XY
	A1SX30		○		XY
	A1SX40		○		XY
	A1SX40-S1		○		XY
	A1SX40-S2		○		XY
	A1SX41		○		XY
	A1SX41-S1		○		XY
	A1SX41-S2		○		XY
	A1SX42		○		XY
	A1SX42-S1		○		XY
	A1SX42-S2		○		XY
	A1SX71		○		XY
	A1SX80		○		XY
	A1SX80-S1		○		XY
	A1SX80-S2		○		XY
	A1SX81		○		XY
	A1SX81-S2		○		XY
A1SX82-S1		○		XY	
Output module	A1SY10		○		XY
	A1SY10EU		○		XY
	A1SY14EU		○		XY
	A1SY18A		○		XY
	A1SY18AEU		○		XY
	A1SY22		○		XY
	A1SY28A		○		XY
	A1SY40		○		XY
	A1SY40P		○		XY
	A1SY41		○		XY
	A1SY41P		○		XY
	A1SY42P		○		XY
	A1SY50		○		XY
	A1SY60		○		XY
	A1SY60E		○		XY
	A1SY68A		○		XY

"Mounting of the A1ADP" field ○ : Mountable × : Not mountable

"Applicable adapter" field XY: A1ADP-XY SP: A1ADP-SP -: Not available

Product	Model	Mounting of the A1ADP			Applicable adapter
		QCPU	QnACPU	ACPU	
Output module	A1SY71		○		XY
	A1SY80		○		XY
	A1SY81		○		XY
	A1SY82		○		XY
I/O module	A1SH42		○		XY
	A1SH42P		○		XY
	A1SH42-S1		○		XY
	A1SH42P-S1		○		XY
	A1SX48Y58		○		XY
	A1SX48Y18		○		XY
	A1SJ-56DR		×		-
	A1SJ-56DT		×		-
	Dynamic scan input module	A1S42X		○	
Dynamic scan output module	A1S42Y		○		XY
Dummy module	A1SG62		○		XY
Interrupt module	A1S61		○		XY ^{*1}
	A1S61PN		×		-
	A1S62PN		×		-
Power supply module	A1S63P		×		-
	A1SP60		○		XY
	A1ST60		○		XY
Analog input module	A1S64AD		○		SP
	A1S68AD		○		SP
Analog output module	A1S62DA		○		SP
	A1S68DAI		○		SP
	A1S68DAV		○		SP
Analog I/O module	A1S63ADA		○		SP
	A1S66ADA		○		XY
Temperature input module	A1S62RD3N		○		SP
	A1S62RD4N		○		SP
	A1S68TD		○		SP
Temperature control module	A1S62TCTT-S2		○		SP
	A1S62TCRTBW-S2		○		SP
	A1S62TCRT-S2		○		SP
	A1S62TCTTBW-S2		○		SP
	A1S64TCTT-S1		○		SP
	A1S64TCTTBW-S1		○		SP
	A1S64TCRT-S1		○		SP
	A1S64TCRTBW-S1		○		SP

"Mounting of the A1ADP" field ○ : Mountable × : Not mountable

"Applicable adapter" field XY: A1ADP-XY SP: A1ADP-SP -: Not available

Product	Model	Mounting of the A1ADP			Applicable adapter
		QCPU	QnACPU	ACPU	
Temperature control module	A1S64TCTRT		○		SP
	A1S64TCTRTBW		○		SP
High-speed counter module	A1SD61		○		SP
	A1SD62		○		SP
	A1SD62E		○		SP
	A1SD62D		○		SP
	A1SD62D-S1		○		SP
Positioning module	A1SD70		×		-
	A1SD75M1		○		SP
	A1SD75M2		○		SP
	A1SD75M3		○		SP
	A1SD75P1-S3		○		SP
	A1SD75P2-S3		○		SP
Position detection module	A1S62LS		○		SP
	A1SD51S		○		SP
Ethernet module	A1SJ71E71N-B2	×	○	○	SP
	A1SJ71E71N-B5	×	○	○	SP
	A1SJ71E71N3-T	×	○	○	SP
	A1SJ71QE71N-B2	×	○	×	SP
	A1SJ71QE71N-B5	×	○	×	SP
	A1SJ71QE71N3-T	×	○	×	SP
Serial communication module	A1SJ71QC24N	×	○	×	SP
	A1SJ71QC24N-R2	×	○	×	SP
	A1SJ71QC24N1	×	○	×	SP
	A1SJ71QC24N1-R2	×	○	×	SP
MELSECNET/B data link module	A1SJ71AT21B	×	○	○	SP
	A1SJ72T25B		×		-
MELSECNET data link module	A1SJ71AP21	×	○	○	SP
	A1SJ71AR21	×	○	○	SP
MELSECNET, MELSECNET/B local station data link module	A1SJ71AP23Q	○	×	×	SP
	A1SJ71AR23Q	○	×	×	SP
	A1SJ71AT23BQ	○	×	×	SP
MELSECNET/10 network module	A1SJ71LP21	×	×	○	SP
	A1SJ71BR11	×	×	○	SP
	A1SJ71LR21	×	×	○	SP
	A1SJ71QLP21	×	○	×	SP
	A1SJ71QLP21S		×		-
	A1SJ71QBR11	×	○	×	SP
	A1SJ71QLR21	×	○	×	SP
CC-Link system master/local module	A1SJ61BT11	×	×	○	SP
	A1SJ61QBT11	○	○	×	SP

"Mounting of the A1ADP" field ○ : Mountable × : Not mountable

"Applicable adapter" field XY: A1ADP-XY SP: A1ADP-SP - : Not available

Product	Model	Mounting of the A1ADP			Applicable adapter
		QCPU	QnACPU	ACPU	
MELSECNET/ MINI-S3 master module	A1SJ71PT32-S3	○			SP
MELSEC-I/O LINK master module	A1SJ51T64	○			SP*1
JEMANET (OPCN-1) interface module	A1SJ71J92-S3	○			SP
	A1SJ72J95	×			-
B/NET interface module	A1SJ71B62-S3	○			SP
Computer link module	A1SJ71UC24-R2	×	○	○	SP
	A1SJ71UC24-PRF	×	○	○	SP
	A1SJ71UC24-R4	○*2	○	○	SP
S-LINK master module	A1SJ71SL92N	○			SP
AS-i master module	A1SJ71AS92	○			SP
Modem interface module	A1SJ71CMO-S3	×	○	○	SP
PC fault detection module	A1SS91	○			SP*1
Memory card interface module	A1SD59J-S2	○			SP
ID interface module	A1SD35ID1	○			SP
	A1SD35ID2	○			SP
MODBUS module	A1SJ71UC24-R2-S2	○			SP
	A1SJ71UC24-R4-S2	○			SP
Profibus-DP interface module	A1SJ71PB92D	○			SP
	A1SJ71PB93D	○			SP
Profibus-FMS interface module	A1SJ71PB96F	○			SP
DeviceNet master module	A1SJ71DN91	○			SP

"Mounting of the A1ADP" field ○ : Mountable × : Not mountable

"Applicable adapter" field XY: A1ADP-XY SP: A1ADP-SP -: Not available

*1 Take care since the combination of the module type configured in the I/O assignment setting and the A1ADP model that can be combined differs.

*2 The adapter is mountable only when the multidrop link function is used.

8. REPLACEABLE MODULES LIST

The following lists the A/QnA (large type) series modules that can be replaced by the A1ADP + AnS series module.

8.1 How to See the List

Product	Related model for discontinuation	Transition to the AnS series			
	A series model	AnS series model		Restrictions	Applicable adapter
Ethernet module	AJ71E71N-B2 670mA	A1SJ71E7 1N-B2 660mA	○	No restrictions	SP
Input module	AX50-S1 55mA	None	×	Alternating with A1SX40 is recommended. 1) External wiring: Changed Connect a 4.7k (1/2W or more) to the external signal wire serially. 2) Number of slots: Not changed 3) Program Number of occupied I/O points: Not changed 4) Specifications Rated input voltage: Not changed Rated input current: Changed ON voltage/ON current: Changed OFF voltage/OFF current: Changed Input resistance: Changed 5) Functions: Not changed	Not used
	i	ii	iii	iv	v

Description

- i ... Classifies the transition list by a product.
- ii... Indicates each module name of the A series and its 5VDC internal current consumption.
- iii... Indicates each module name of the AnS series and its 5VDC internal current consumption.

5VDC internal current consumption for the A1ADP + AnS series module is calculated by adding the 5VDC internal current consumption for the A1ADP to this value.

For the A1ADP-XY : The value above + 3.4mA

For the A1ADP-SP : The value above + 0mA

- iv... Indicates whether any restriction is given or not when mounting the A1ADP + AnS module (A module with the name provided in the Model column.).

○	No restrictions
△	Partially restricted. The restriction outline is described in the Remark (restrictions) column.
×	No alternative model The alternating method is described in the Remark (restrictions) column.
× (△ as for specifications)	The performance specifications are compatible while the module cannot be mounted due to the expanded module width.

- v... Indicates whether any restriction is given or not when mounting the A1ADP + AnS module (A module with the name provided in the Model column.).

XY	A1ADP-XY (An adapter only for I/O modules)
SP	A1ADP-SP (An adapter only for special function modules)
Not used	Either of the A1ADPs cannot be installed.

POINT	
(1)	When replacing the A series module by the A1ADP + AnS series module, the internal current consumption may increase. At replacement, make sure to check the 5VDC internal current consumption of the modules before and after replacement. If the 5VDC internal current consumption increases after the replacement, confirm that the current consumption of the modules used does not exceed the rated output current of the power supply module used.
(2)	If the A1ADP + AnS series module is mounted to an extension base unit (type requiring no power supply module) (A52B, A55B, or A58B) when 5VDC internal current consumption is increased, voltage drop increases in the extension cable. Therefore, recalculating the receiving end voltage is required. (For confirmation method, refer to the "Application standards of Extension Base Units" (A52B, A55B, or A58B) in the CPU module's User's Manual.)
(3)	If the execution of (1) or (2) results in excess of rated output current of a power supply module, or drop of receiving end voltage to less than 4.75VDC, take the following measures. <ol style="list-style-type: none"> 1) Review the system configuration. 2) Do not use the transition models.
(4)	As for the following nine models, the current consumption is greatly increased by the transition. Pay special attention to the models in (1) to (3) above. <ol style="list-style-type: none"> 1) AY41(-UL)(230mA) → A1SY41(500mA)^{*1} 2) AY70(100mA) → A1SY71(400mA) 3) AY81(230mA) → A1SY81(500mA) 4) AY82EP(290mA) → A1SY82(930mA) 5) AH42(245mA) → A1SH42(500mA) 6) A68DAI-S1(150mA) → A1S68DAI(850mA) 7) A68DAV(150mA) → A1S68DAV(650mA) 8) AJ71E71N-T(400mA) → A1SJ71E71N3-T(690mA)
	^{*1} For this model, refer to A1SY4□P in the transition lists from Section 8.2 to Section 8.4. For replacement with the A1SY4□, refer to the manual for the specifications.

8.2 List of Transition from the A Series to AnS Series

Product	Related model for discontinuation	Transition to the AnS series			
	A series model	AnS series model	Restrictions	Applicable adapter	
Input module	AX10	A1SX10	△	1) External wiring: Changed Screw size: M3→M3.5 2) Number of slots: Not changed 3) Program Number of occupied I/O points: Not changed 4) Specifications Rated input voltage: Not changed Rated input current: Changed ON voltage/ON current: Changed OFF voltage/OFF current: Changed Input resistance: Changed 5) Functions: Not changed	XY
	55mA	50mA			
	AX10-UL	A1SX10	△	1) External wiring: Changed Screw size: M3→M3.5 2) Number of slots: Not changed 3) Program Number of occupied I/O points: Not changed 4) Specifications Rated input voltage: Not changed Rated input current: Changed ON voltage/ON current: Changed OFF voltage/OFF current: Changed Input resistance: Changed 5) Functions: Not changed	XY
	55mA	50mA			
	AX11	A1SX10	△	1) External wiring: Changed Screw size: M3→M3.5 2) Number of slots: Changed (2 modules required) 3) Program Number of occupied I/O points: Not changed (32=16×2) 4) Specifications Rated input voltage: Not changed Rated input current: Changed ON voltage/ON current: Changed OFF voltage/OFF current: Changed Input resistance: Changed 5) Functions: Not changed	XY
	110mA	50mA			

Product	Related model for discontinuation	Transition to the AnS series		
	A series model	AnS series model	Restrictions	Applicable adapter
Input module	AX11EU	A1SX10 EU	Δ 1) External wiring: Changed 2) Number of slots: Changed (2 modules required) 3) Program Number of occupied I/O points: Not changed (32=16×2) 4) Specifications Rated input voltage: Not changed Rated input current: Changed ON voltage/ON current: Changed OFF voltage/OFF current: Changed Input resistance: Changed 5) Functions: Not changed	XY
	150mA	50mA		
	AX20	A1SX20	Δ 1) External wiring: Changed Screw size: M3→M3.5 2) Number of slots: Not changed 3) Program Number of occupied I/O points: Not changed 4) Specifications Rated input voltage: Not changed Rated input current: Changed ON voltage/ON current: Changed OFF voltage/OFF current: Changed Input resistance: Changed 5) Functions: Not changed	XY
	55mA	50mA		
	AX20-UL	A1SX20	Δ 1) External wiring: Changed Screw size: M3→M3.5 2) Number of slots: Not changed 3) Program Number of occupied I/O points: Not changed 4) Specifications Rated input voltage: Not changed Rated input current: Changed ON voltage/ON current: Changed OFF voltage/OFF current: Changed Input resistance: Changed 5) Functions: Not changed	XY
	55mA	50mA		

Product	Related model for discontinuation	Transition to the AnS series		
	A series model	AnS series model	Restrictions	Applicable adapter
Input module	AX21	A1SX20	△ 1) External wiring: Changed Screw size: M3→M3.5 2) Number of slots: Changed (2 modules required) 3) Program Number of occupied I/O points: Not changed (32=16×2) 4) Specifications Rated input voltage: Changed Rated input current: Changed ON voltage/ON current: Changed OFF voltage/OFF current: Changed Input resistance: Changed	XY
	110mA	50mA	5) Functions: Not changed	
	AX21EU	A1SX20 EU	△ 1) External wiring: Changed 2) Number of slots: Changed (2 modules required) 3) Program Number of occupied I/O points: Not changed (32=16×2) 4) Specifications Rated input voltage: Not changed Rated input current: Changed ON voltage/ON current: Changed OFF voltage/OFF current: Changed Input resistance: Changed	XY
150mA	50mA	5) Functions: Not changed		
	AX31	A1SX30	△ 1) External wiring: Changed Screw size: M3→M3.5 2) Number of slots: Changed (2 modules required) 3) Program Number of occupied I/O points: Not changed (32=16×2) 4) Specifications Rated input voltage: Changed Rated input current: Changed ON voltage/ON current: Changed OFF voltage/OFF current: Changed Input resistance: Changed	XY
	110mA	50mA	5) Functions: Not changed	

Product	Related model for discontinuation	Transition to the AnS series		
	A series model	AnS series model	Restrictions	Applicable adapter
Input module	AX31-S1	A1SX41	△ 1) External wiring: Changed (Connector terminal block must be converted.) 2) Number of slots: Not changed 3) Program Number of occupied I/O points: Not changed 4) Specifications Rated input voltage: Not changed Rated input current: Changed ON voltage/ON current: Changed OFF voltage/OFF current: Changed Input resistance: Changed	XY
	110mA	80mA	5) Functions: Not changed	
	AX40	A1SX40	△ 1) External wiring: Changed Screw size: M3→M3.5 2) Number of slots: Not changed 3) Program Number of occupied I/O points: Not changed 4) Specifications Rated input voltage: Not changed Rated input current: Changed ON voltage/ON current: Changed OFF voltage/OFF current: Changed Input resistance: Changed	XY
	55mA	50mA	5) Functions: Not changed	
55mA	AX40-UL	A1SX40	△ 1) External wiring: Changed 2) Number of slots: Not changed 3) Program Number of occupied I/O points: Not changed 4) Specifications Rated input voltage: Not changed Rated input current: Changed ON voltage/ON current: Changed OFF voltage/OFF current: Changed Input resistance: Changed	XY
	55mA	50mA	5) Functions: Not changed	

Product	Related model for discontinuation	Transition to the AnS series		
	A series model	AnS series model	Restrictions	Applicable adapter
Input module	AX41	A1SX41	△ 1) External wiring: Changed (Connector terminal block must be converted.) 2) Number of slots: Not changed 3) Program Number of occupied I/O points: Not changed 4) Specifications Rated input voltage: Not changed Rated input current: Changed ON voltage/ON current: Changed OFF voltage/OFF current: Changed Input resistance: Changed	XY
	110mA	80mA	5) Functions: Not changed	
	AX41-UL	A1SX41	△ 1) External wiring: Changed (Connector terminal block must be converted.) 2) Number of slots: Not changed 3) Program Number of occupied I/O points: Not changed 4) Specifications Rated input voltage: Not changed Rated input current: Changed ON voltage/ON current: Changed OFF voltage/OFF current: Changed Input resistance: Changed	XY
110mA	80mA	5) Functions: Not changed		
	AX41-S1	A1SX41-S1	△ 1) External wiring: Changed (Connector terminal block must be converted.) 2) Number of slots: Not changed 3) Program Number of occupied I/O points: Not changed 4) Specifications Rated input voltage: Changed (12VDC not applicable) Rated input current: Changed ON voltage/ON current: Changed OFF voltage/OFF current: Changed Input resistance: Changed 5) Functions: Not changed 6) Since internal current consumption increases by combination with the A1ADP-XY, checking power capacity and receiving end voltage is required (Refer to POINT (1) to (3)).	XY
	110mA	120mA		

Product	Related model for discontinuation	Transition to the AnS series		
	A series model	AnS series model	Restrictions	Applicable adapter
Input module	AX42	A1SX42	△ 1) External wiring: Not changed 2) Number of slots: Not changed 3) Program Number of occupied I/O points: Not changed 4) Specifications Rated input voltage: Not changed Rated input current: Changed ON voltage/ON current: Changed OFF voltage/OFF current: Changed Input resistance: Changed 5) Functions: Not changed	XY
	120mA	90mA		
	AX42-S1	A1SX42-S1	△ 1) External wiring: Not changed 2) Number of slots: Not changed 3) Program Number of occupied I/O points: Not changed 4) Specifications Rated input voltage: Changed (12VDC not applicable) Rated input current: Changed ON voltage/ON current: Changed OFF voltage/OFF current: Changed Input resistance: Changed 5) Functions: Not changed 6) Since internal current consumption increases by combination with the A1ADP-XY, checking power capacity and receiving end voltage is required (Refer to POINT (1) to (3)).	XY
	120mA	160mA		
	AX50-S1	None	× Alternating with A1SX40 is recommended. 1) External wiring: Changed Connect a 4.7kΩ (1/2W or more) to the external signal wire serially. 2) Number of slots: Not changed 3) Program Number of occupied I/O points: Not changed 4) Specifications Rated input voltage: Changed Rated input current: Changed ON voltage/ON current: Changed OFF voltage/OFF current: Changed Input resistance: Changed 5) Functions: Not changed	Not used
	55mA			

Product	Related model for discontinuation	Transition to the AnS series			
	A series model	AnS series model	Restrictions	Applicable adapter	
Input module	AX60-S1	None	×	<p>Alternating with A1SX40 is recommended.</p> <p>1) External wiring: Changed Connect a 15kΩ (3W or more) to the external signal wire serially.</p> <p>2) Number of slots: Not changed</p> <p>3) Program Number of occupied I/O points: Not changed</p> <p>4) Specifications Rated input voltage: Changed Rated input current: Changed ON voltage/ON current: Changed OFF voltage/OFF current: Changed Input resistance: Changed</p> <p>5) Functions: Not changed</p>	Not used
	55mA				
	AX70	A1SX71	△	<p>1) External wiring: Changed (Connector terminal block must be converted.)</p> <p>2) Number of slots: Not changed</p> <p>3) Program Number of occupied I/O points: Changed</p> <p>4) Specifications Rated input voltage: Not changed Rated input current: Changed ON voltage/ON current: Changed OFF voltage/OFF current: Changed Input resistance: Changed</p> <p>5) Functions: Not changed</p> <p>6) Since internal current consumption increases by combination with the A1ADP-XY, checking power capacity and receiving end voltage is required (Refer to POINT (1) to (3)).</p>	XY
	55mA	75mA			

Product	Related model for discontinuation	Transition to the AnS series		
	A series model	AnS series model	Restrictions	Applicable adapter
Input module	AX70-UL	A1SX71	△ 1) External wiring: Changed (Connector terminal block must be converted.) 2) Number of slots: Not changed 3) Program Number of occupied I/O points: Changed 4) Specifications Rated input voltage: Not changed Rated input current: Changed ON voltage/ON current: Changed OFF voltage/OFF current: Changed Input resistance: Changed 5) Functions: Not changed 6) Since internal current consumption increases by combination with the A1ADP-XY, checking power capacity and receiving end voltage is required (Refer to POINT (1) to (3)).	XY
	55mA	75mA		
	AX71	A1SX71	△ 1) External wiring: Changed (Connector terminal block must be converted.) 2) Number of slots: Not changed 3) Program Number of occupied I/O points: Not changed 4) Specifications Rated input voltage: Not changed Rated input current: Changed ON voltage/ON current: Changed OFF voltage/OFF current: Changed Input resistance: Changed 5) Functions: Not changed	XY
	110mA	75mA		
	AX80	A1SX80	△ 1) External wiring: Changed 2) Number of slots: Not changed 3) Program Number of occupied I/O points: Not changed 4) Specifications Rated input voltage: Not changed Rated input current: Changed ON voltage/ON current: Changed OFF voltage/OFF current: Changed Input resistance: Changed 5) Functions: Not changed	XY
	55mA	50mA		

Product	Related model for discontinuation	Transition to the AnS series		
	A series model	AnS series model	Restrictions	Applicable adapter
Input module	AX80-UL	A1SX80	△ 1) External wiring: Changed 2) Number of slots: Not changed 3) Program Number of occupied I/O points: Not changed 4) Specifications Rated input voltage: Not changed Rated input current: Changed ON voltage/ON current: Changed OFF voltage/OFF current: Changed Input resistance: Changed 5) Functions: Not changed	XY
	55mA	50mA		
	AX80E	A1SX80-S1	△ 1) External wiring: Changed Screw size: M3→M3.5 2) Number of slots: Not changed 3) Program Number of occupied I/O points: Not changed 4) Specifications Rated input voltage: Changed (12VDC not applicable) Rated input current: Changed ON voltage/ON current: Changed OFF voltage/OFF current: Changed Input resistance: Changed 5) Functions: Not changed	XY
	55mA	50mA		
	AX81	A1SX81	△ 1) External wiring: Changed (Connector terminal block must be converted.) 2) Number of slots: Not changed 3) Program Number of occupied I/O points: Not changed 4) Specifications Rated input voltage: Not changed Rated input current: Changed ON voltage/ON current: Changed OFF voltage/OFF current: Changed Input resistance: Changed 5) Functions: Not changed	XY
	110mA	80mA		

Product	Related model for discontinuation	Transition to the AnS series		
	A series model	AnS series model	Restrictions	Applicable adapter
Input module	AX81B	None	× Alternating with A1SX81 is recommended. 1) External wiring: Changed (Connector terminal block must be converted.) 2) Number of slots: Not changed 3) Program Number of occupied I/O points: Changed 4) Specifications Rated input voltage: Not changed Rated input current: Changed ON voltage/ON current: Changed OFF voltage/OFF current: Changed Input resistance: Changed 5) Functions: The wire breakage detection function not provided	Not used
	55mA			
	AX81-S1	A1SX81	△ 1) External wiring: Changed (Connector terminal block must be converted.) 2) Number of slots: Not changed 3) Program Number of occupied I/O points: Not changed 4) Specifications Rated input voltage: Not changed Rated input current: Changed ON voltage/ON current: Changed OFF voltage/OFF current: Changed Input resistance: Changed 5) Functions: Not changed	XY
	105mA	80mA		

Product	Related model for discontinuation	Transition to the AnS series			
	A series model	AnS series model	Restrictions	Applicable adapter	
Input module	AX81-S2	None	×	<p>Alternating with A1SX81 is recommended.</p> <p>1) External wiring: Changed (Connector terminal block must be converted.) Connect a 3.3kΩ (1/2W or more) or 8.2kΩ (1W or more) resistor serially to the external signal wire at 48VDC or 60VDC, respectively.</p> <p>2) Number of slots: Not changed</p> <p>3) Program Number of occupied I/O points: Not changed</p> <p>4) Specifications Rated input voltage: Changed Rated input current: Changed ON voltage/ON current: Changed OFF voltage/OFF current: Changed Input resistance: Changed</p> <p>5) Functions: Not changed</p>	Not used
	110mA				
	AX81-S3	A1SX80-S1	△	<p>1) External wiring: Changed Screw size: M3→M3.5</p> <p>2) Number of slots: Changed (2 modules required)</p> <p>3) Program Number of occupied I/O points: Changed</p> <p>4) Specifications Rated input voltage: Changed (12VDC not applicable) Rated input current: Changed ON voltage/ON current: Changed OFF voltage/OFF current: Changed Input resistance: Changed</p> <p>5) Functions: Not changed</p>	XY
	110mA	50mA			

Product	Related model for discontinuation	Transition to the AnS series		
	A series model	AnS series model	Restrictions	Applicable adapter
Input module	AX82	A1SX82-S1	△ 1) External wiring: Changed (D sub→FCN connector) 2) Number of slots: Not changed 3) Program Number of occupied I/O points: Not changed 4) Specifications Rated input voltage: Changed (12VDC not applicable) Rated input current: Changed ON voltage/ON current: Changed OFF voltage/OFF current: Changed Input resistance: Changed 5) Functions: Not changed 6) Since internal current consumption increases by combination with the A1ADP-XY, checking power capacity and receiving end voltage is required (Refer to POINT (1) to (3)).	XY
	120mA	160mA		
Output module	AY10	A1SY10	△ 1) External wiring: Changed 2) Number of slots: Not changed 3) Program Number of occupied I/O points: Not changed 4) Specifications Rated output voltage: Not changed Rated output current: Not changed (However, contact life span is reduced to half.) 5) Functions: Not changed 6) Since internal current consumption increases by combination with the A1ADP-XY, checking power capacity and receiving end voltage is required (Refer to POINT (1) to (3)).	XY
	115mA	120mA		

Product	Related model for discontinuation	Transition to the AnS series		
	A series model	AnS series model	Restrictions	Applicable adapter
Output module	AY10A 115mA	A1SY18 A 240mA	△ 1) External wiring: Changed 2) Number of slots: Changed (2 modules required) 3) Program Number of occupied I/O points: Changed 4) Specifications Rated output voltage: Not changed Rated output current: Not changed 5) Functions: Not changed 6) Since internal current consumption increases by combination with the A1ADP-XY, checking power capacity and receiving end voltage is required (Refer to POINT (1) to (3)).	XY
	AY10A-UL 115mA	A1SY18 A 240mA	△ 1) External wiring: Changed 2) Number of slots: Changed (2 modules required) 3) Program Number of occupied I/O points: Changed 4) Specifications Rated output voltage: Not changed Rated output current: Not changed 5) Functions: Not changed 6) Since internal current consumption increases by combination with the A1ADP-XY, checking power capacity and receiving end voltage is required (Refer to POINT (1) to (3)).	XY
	AY11 115mA	A1SY10 120mA	△ 1) External wiring: Changed 2) Number of slots: Not changed 3) Program Number of occupied I/O points: Not changed 4) Specifications Rated output voltage: Not changed Rated output current: Not changed (However, contact life span is reduced to half.) 5) Functions: Changed (No varistor, relay not replaceable) 6) Since internal current consumption increases by combination with the A1ADP-XY, checking power capacity and receiving end voltage is required (Refer to POINT (1) to (3)).	XY

Product	Related model for discontinuation	Transition to the AnS series		
	A series model	AnS series model	Restrictions	Applicable adapter
Output module	AY11A 115mA	A1SY18 A 240mA	△ 1) External wiring: Changed 2) Number of slots: Changed (2 modules required) 3) Program Number of occupied I/O points: Changed 4) Specifications Rated output voltage: Not changed Rated output current: Not changed 5) Functions: Changed (No varistor) 6) Since internal current consumption increases by combination with the A1ADP-XY, checking power capacity and receiving end voltage is required (Refer to POINT (1) to (3)).	XY
	AY11AEU 115mA	A1SY18 AEU 240mA	△ 1) External wiring: Changed 2) Number of slots: Changed (2 modules required) 3) Program Number of occupied I/O points: Changed 4) Specifications Rated output voltage: Not changed Rated output current: Not changed 5) Functions: Changed (No varistor) 6) Since internal current consumption increases by combination with the A1ADP-XY, checking power capacity and receiving end voltage is required (Refer to POINT (1) to (3)).	XY
	AY11E 115mA	A1SY10 120mA	△ 1) External wiring: Changed 2) Number of slots: Not changed 3) Program Number of occupied I/O points: Not changed 4) Specifications Rated output voltage: Not changed Rated output current: Not changed (However, contact life span is reduced to half.) 5) Functions: Changed (No fuse, no varistor) 6) Since internal current consumption increases by combination with the A1ADP-XY, checking power capacity and receiving end voltage is required (Refer to POINT (1) to (3)).	XY

Product	Related model for discontinuation	Transition to the AnS series		
	A series model	AnS series model	Restrictions	Applicable adapter
Output module	AY11EEU 115mA	A1SY10 EU 120mA	Δ 1) External wiring: Changed 2) Number of slots: Not changed 3) Program Number of occupied I/O points: Not changed 4) Specifications Rated output voltage: Not changed Rated output current: Not changed (However, contact life span is reduced to half.) 5) Functions: Changed (No fuse, no varistor) 6) Since internal current consumption increases by combination with the A1ADP-XY, checking power capacity and receiving end voltage is required (Refer to POINT (1) to (3)).	XY
	AY11-UL 115mA	A1SY10 120mA	Δ 1) External wiring: Changed 2) Number of slots: Not changed 3) Program Number of occupied I/O points: Not changed 4) Specifications Rated output voltage: Not changed Rated output current: Not changed (However, contact life span is reduced to half.) 5) Functions: Changed (No varistor) 6) Since internal current consumption increases by combination with the A1ADP-XY, checking power capacity and receiving end voltage is required (Refer to POINT (1) to (3)).	XY

Product	Related model for discontinuation	Transition to the AnS series		
	A series model	AnS series model	Restrictions	Applicable adapter
Output module	AY13	A1SY10	Δ 1) External wiring: Changed 2) Number of slots: Changed (2 modules required) Since internal current consumption increases by combination with the A1ADP-XY, when using the two modules, checking power capacity and receiving end voltage is required (Refer to POINT (1) to (3)). 3) Program Number of occupied I/O points: Not changed (32=16×2) 4) Specifications Rated output voltage: Not changed Rated output current: Not changed (However, contact life span is reduced to half.) 5) Functions: Not changed	XY
	230mA	120mA	5) Functions: Not changed	
	AY13E	A1SY10	Δ 1) External wiring: Changed 2) Number of slots: Changed (2 modules required) Since internal current consumption increases by combination with the A1ADP-XY, when using the two modules, checking power capacity and receiving end voltage is required (Refer to POINT (1) to (3)). 3) Program Number of occupied I/O points: Not changed (32=16×2) 4) Specifications Rated output voltage: Not changed Rated output current: Not changed (However, contact life span is reduced to half.) 5) Functions: Changed (No fuse)	
	230mA	120mA	5) Functions: Changed (No fuse)	

Product	Related model for discontinuation	Transition to the AnS series		
	A series model	AnS series model	Restrictions	Applicable adapter
Output module	AY13EU	A1SY10 EU	△ 1) External wiring: Changed 2) Number of slots: Changed (2 modules required) Since internal current consumption increases by combination with the A1ADP-XY, when using the two modules, checking power capacity and receiving end voltage is required (Refer to POINT (1) to (3)). 3) Program Number of occupied I/O points: Not changed (32=16×2) 4) Specifications Rated output voltage: Not changed Rated output current: Not changed (However, contact life span is reduced to half.) 5) Functions: Not changed	XY
	230mA	120mA	5) Functions: Not changed	
	AY15EU	A1SY14 EU	△ 1) External wiring: Changed 2) Number of slots: Changed (2 modules required) Since internal current consumption increases by combination with the A1ADP-XY, when using the two modules, checking power capacity and receiving end voltage is required (Refer to POINT (1) to (3)). 3) Program Number of occupied I/O points: Not changed (32=16×2) 4) Specifications Rated output voltage: Not changed Rated output current: Not changed (However, contact life span is reduced to half.) 5) Functions: Not changed	XY
150mA	120mA	5) Functions: Not changed		
	AY22	A1SY22	△ 1) External wiring: Changed 2) Number of slots: Not changed 3) Program Number of occupied I/O points: Not changed 4) Specifications Rated output voltage: Not changed Rated output current: Changed (Output 2A→0.6A) 5) Functions: Changed (No fuse, no varistor)	XY
	305mA	270mA		

Product	Related model for discontinuation	Transition to the AnS series		
	A series model	AnS series model	Restrictions	Applicable adapter
Output module	AY23 590mA	A1SY22 270mA	Δ 1) External wiring: Changed 2) Number of slots: Changed (2 modules required) 3) Program Number of occupied I/O points: Not changed (32=16×2) 4) Specifications Rated output voltage: Not changed Rated output current: Not changed 5) Functions: Changed (No fast blow fuse)	XY
	AY40 115mA	A1SY40 P 79mA	Δ 1) External wiring: Changed 2) Number of slots: Not changed 3) Program Number of occupied I/O points: Not changed 4) Specifications Rated output voltage: Not changed Rated output current: Not changed 5) Functions: Not changed	XY
	AY40-UL 115mA	A1SY40 P 79mA	Δ 1) External wiring: Changed 2) Number of slots: Not changed 3) Program Number of occupied I/O points: Not changed 4) Specifications Rated output voltage: Not changed Rated output current: Not changed 5) Functions: Not changed	XY
	AY40A 190mA	A1SY68 A 110mA	Δ 1) External wiring: Changed 2) Number of slots: Changed (2 modules required) Since internal current consumption increases by combination with the A1ADP-XY, when using the two modules, checking power capacity and receiving end voltage is required (Refer to POINT (1) to (3)). 3) Program Number of occupied I/O points: Changed 4) Specifications Rated output voltage: Not changed Rated output current: Not changed Response: Slow 5) Functions: Not changed	XY

Product	Related model for discontinuation	Transition to the AnS series			
	A series model	AnS series model		Restrictions	Applicable adapter
Output module	AY41	A1SY41 P	△	1) External wiring: Changed (Connector terminal block must be converted.) 2) Number of slots: Not changed 3) Program Number of occupied I/O points: Not changed 4) Specifications Rated output voltage: Not changed Rated output current: Not changed 5) Functions: Not changed	XY
	230mA	141mA			
	AY41-UL	A1SY41 P	△	1) External wiring: Changed (Connector terminal block must be converted.) 2) Number of slots: Not changed 3) Program Number of occupied I/O points: Not changed 4) Specifications Rated output voltage: Not changed Rated output current: Not changed 5) Functions: Not changed	XY
	230mA	141mA			
	AY42	A1SY42 P	○	1) External wiring: Not changed 2) Number of slots: Not changed 3) Program Number of occupied I/O points: Not changed 4) Specifications Rated output voltage: Not changed Rated output current: Not changed 5) Functions: Not changed	XY
	340mA	170mA			
	AY42-S1	A1SY42 P	△	1) External wiring: Not changed 2) Number of slots: Not changed 3) Program Number of occupied I/O points: Not changed 4) Specifications Rated output voltage: Not changed Rated output current: Not changed Response time: Changed (from 0.3ms to 1ms or less) 5) Functions: Not changed	XY
	290mA	170mA			

Product	Related model for discontinuation	Transition to the AnS series		
	A series model	AnS series model	Restrictions	Applicable adapter
Output module	AY42-S3 290mA	A1SY42P 170mA	○ 1) External wiring: Not changed 2) Number of slots: Not changed 3) Program Number of occupied I/O points: Not changed 4) Specifications Rated output voltage: Not changed Rated output current: Not changed 5) Functions: Changed (The short protection function equivalent to fuse included)	XY
	AY42-S4 500mA	A1SY42P 170mA	△ 1) External wiring: Changed (External supply power is required.) 2) Number of slots: Not changed 3) Program Number of occupied I/O points: Not changed 4) Specifications Rated output voltage: Not changed Rated output current: Not changed 5) Functions: Not changed	XY
	AY50 115mA	A1SY50 120mA	△ 1) External wiring: Changed 2) Number of slots: Not changed 3) Program Number of occupied I/O points: Not changed 4) Specifications Rated output voltage: Not changed Rated output current: Not changed 5) Functions: Changed (Fuse not replaceable) 6) Since internal current consumption increases by combination with the A1ADP-XY, checking power capacity and receiving end voltage is required (Refer to POINT (1) to (3)).	XY

Product	Related model for discontinuation	Transition to the AnS series			
	A series model	AnS series model	Restrictions	Applicable adapter	
Output module	AY50-UL	A1SY50	△	1) External wiring: Changed 2) Number of slots: Not changed 3) Program Number of occupied I/O points: Not changed 4) Specifications Rated output voltage: Not changed Rated output current: Not changed 5) Functions: Changed (Fuse not replaceable) 6) Since internal current consumption increases by combination with the A1ADP-XY, checking power capacity and receiving end voltage is required (Refer to POINT (1) to (3)).	XY
	115mA	120mA			
	AY51	A1SY50	△	1) External wiring: Changed 2) Number of slots: Changed (2 modules required) Since internal current consumption increases by combination with the A1ADP-XY, when using the two modules, checking power capacity and receiving end voltage is required (Refer to POINT (1) to (3)). 3) Program Number of occupied I/O points: Not changed (32=16×2) 4) Specifications Rated output voltage: Not changed Rated output current: Not changed 5) Functions: Not changed	XY
	230mA	120mA			

Product	Related model for discontinuation	Transition to the AnS series		
	A series model	AnS series model	Restrictions	Applicable adapter
Output module	AY51-S1	A1SY50	△ 1) External wiring: Changed 2) Number of slots: Changed (2 modules required) Since internal current consumption increases by combination with the A1ADP-XY, when using the two modules, checking power capacity and receiving end voltage is required (Refer to POINT (1) to (3)). 3) Program Number of occupied I/O points: Not changed (32=16×2) 4) Specifications Rated output voltage: Not changed Rated output current: Not changed 5) Functions: Changed (Fuse not replaceable)	XY
	230mA	120mA		
	AY51-UL	A1SY50	△ 1) External wiring: Changed 2) Number of slots: Changed (2 modules required) Since internal current consumption increases by combination with the A1ADP-XY, when using the two modules, checking power capacity and receiving end voltage is required (Refer to POINT (1) to (3)). 3) Program Number of occupied I/O points: Not changed (32=16×2) 4) Specifications Rated output voltage: Not changed Rated output current: Not changed 5) Functions: Not changed	XY
	230mA	120mA		
	AY60	A1SY60	△ 1) External wiring: Changed 2) Number of slots: Not changed 3) Program Number of occupied I/O points: Not changed 4) Specifications Rated output voltage: Changed (48VDC not applicable) Rated output current: Not changed 5) Functions: Not changed 6) Since internal current consumption increases by combination with the A1ADP-XY, checking power capacity and receiving end voltage is required (Refer to POINT (1) to (3)).	XY
	115mA	120mA		

Product	Related model for discontinuation	Transition to the AnS series		
	A series model	AnS series model	Restrictions	Applicable adapter
Output module	AY60E	A1SY60E	△ 1) External wiring: Changed 2) Number of slots: Not changed 3) Program Number of occupied I/O points: Not changed 4) Specifications Rated output voltage: Changed (48VDC not applicable) Rated output current: Not changed 5) Functions: Not changed 6) Since internal current consumption increases by combination with the A1ADP-XY, checking power capacity and receiving end voltage is required (Refer to POINT (1) to (3)).	XY
	115mA	200mA		
	AY60S	A1SY60	△ 1) External wiring: Changed 2) Number of slots: Not changed 3) Program Number of occupied I/O points: Changed 4) Specifications Rated output voltage: Changed (48VDC not applicable) Rated output current: Not changed 5) Functions: Not changed 6) Since internal current consumption increases by combination with the A1ADP-XY, checking power capacity and receiving end voltage is required (Refer to POINT (1) to (3)).	XY
	75mA	120mA		
	AY60S-UL	A1SY60	△ 1) External wiring: Changed 2) Number of slots: Not changed 3) Program Number of occupied I/O points: Changed 4) Specifications Rated output voltage: Changed (48VDC not applicable) Rated output current: Not changed 5) Functions: Not changed 6) Since internal current consumption increases by combination with the A1ADP-XY, checking power capacity and receiving end voltage is required (Refer to POINT (1) to (3)).	XY
	75mA	120mA		

Product	Related model for discontinuation	Transition to the AnS series		
	A series model	AnS series model	Restrictions	Applicable adapter
Output module	AY70 100mA	A1SY71 400mA	△ 1) External wiring: Changed (Connector terminal block must be converted.) 2) Number of slots: Not changed 3) Program Number of occupied I/O points: Changed 4) Specifications Rated output voltage: Not changed Rated output current: Not changed 5) Functions: Not changed 6) Since internal current consumption increases by combination with the A1ADP-XY, checking power capacity and receiving end voltage is required (Refer to POINT (1) to (3)).	XY
	AY70-UL 100mA	A1SY71 400mA	△ 1) External wiring: Changed (Connector terminal block must be converted.) 2) Number of slots: Not changed 3) Program Number of occupied I/O points: Changed 4) Specifications Rated output voltage: Not changed Rated output current: Not changed 5) Functions: Not changed 6) Since internal current consumption increases by combination with the A1ADP-XY, checking power capacity and receiving end voltage is required (Refer to POINT (1) to (3)).	XY
	AY71 200mA	A1SY71 400mA	△ 1) External wiring: Changed (Connector terminal block must be converted.) 2) Number of slots: Not changed 3) Program Number of occupied I/O points: Not changed 4) Specifications Rated output voltage: Not changed Rated output current: Not changed 5) Functions: Not changed 6) Since internal current consumption increases by combination with the A1ADP-XY, checking power capacity and receiving end voltage is required (Refer to POINT (1) to (3)).	XY

Product	Related model for discontinuation	Transition to the AnS series		
	A series model	AnS series model	Restrictions	Applicable adapter
Output module	AY72	A1SY71	△ 1) External wiring: Not changed 2) Number of slots: Changed (2 modules required) 3) Program Number of occupied I/O points: Not changed (64=32×2) 4) Specifications Rated output voltage: Not changed Rated output current: Not changed 5) Functions: Not changed 6) Since internal current consumption increases by combination with the A1ADP-XY, checking power capacity and receiving end voltage is required (Refer to POINT (1) to (3)).	XY
	300mA	400mA		
	AY80	A1SY80	△ 1) External wiring: Changed 2) Number of slots: Not changed 3) Program Number of occupied I/O points: Not changed 4) Specifications Rated output voltage: Not changed Rated output current: Not changed 5) Functions: Changed (Fuse not replaceable) 6) Since internal current consumption increases by combination with the A1ADP-XY, checking power capacity and receiving end voltage is required (Refer to POINT (1) to (3)).	
	115mA	120mA		
	AY81	A1SY81	△ 1) External wiring: Changed (Connector terminal block must be converted.) 2) Number of slots: Not changed 3) Program Number of occupied I/O points: Not changed 4) Specifications Rated output voltage: Not changed Rated output current: Changed (Output 0.5A→0.1A) 5) Functions: Not changed 6) Since internal current consumption increases by combination with the A1ADP-XY, checking power capacity and receiving end voltage is required (Refer to POINT (1) to (3)).	XY
	230mA	500mA		

Product	Related model for discontinuation	Transition to the AnS series		
	A series model	AnS series model	Restrictions	Applicable adapter
Output module	AY82EP	A1SY82	△ 1) External wiring: Changed (D sub→FCN connector) 2) Number of slots: Not changed 3) Program Number of occupied I/O points: Not changed 4) Specifications Rated output voltage: Not changed Rated output current: Not changed 5) Functions: Not changed 6) Since internal current consumption increases by combination with the A1ADP-XY, checking power capacity and receiving end voltage is required (Refer to POINT (1) to (3)).	XY
	290mA	930mA		
I/O module	AH42	A1SH42	△ 1) External wiring: Not changed 2) Number of slots: Not changed 3) Program Number of occupied I/O points: Changed (32 points occupied) 4) Specifications Rated output voltage: Changed (12VDC not applicable) Rated output current: Changed ON voltage/ON current: Changed OFF voltage/OFF current: Changed Input resistance: Changed 5) Functions: Not changed 6) Since internal current consumption increases by combination with the A1ADP-XY, checking power capacity and receiving end voltage is required (Refer to POINT (1) to (3)).	XY
		500mA		
			A1SH42 P	△ 1) External wiring: Not changed 2) Number of slots: Not changed 3) Program Number of occupied I/O points: Changed (32 points occupied) 4) Specifications Rated input voltage: Changed (12VDC not applicable) Rated input current: Changed ON voltage/ON current: Changed OFF voltage/OFF current: Changed Input resistance: Changed 5) Functions: Not changed
	245mA	130mA		

Product	Related model for discontinuation	Transition to the AnS series		
	A series model	AnS series model	Restrictions	Applicable adapter
Dynamic scan I/O module	A42XY 110mA	A1S42X 80mA A1S42Y 180mA	△ 1) External wiring: Changed 2) Number of slots: Changed Since internal current consumption increases by combination with the A1ADP-XY, when using the two modules, checking power capacity and receiving end voltage is required (Refer to POINT (1) to (3)). 3) Program Number of occupied I/O points: Changed (128 points occupied: 64×2) 4) Specifications Rated output voltage: Changed (12VDC not applicable) Rated output current: Changed ON voltage/ON current: Changed OFF voltage/OFF current: Changed Input resistance: Changed 5) Functions: Not changed	XY
Dummy module	AG62 70mA	A1SG6 2 60mA	○ No restrictions	XY
Blanking module	AG60	A1SG6 0	○ No restrictions	XY/SP
Interrupt module	AI61 140mA	A1SI61 57mA	△ 1) External wiring: Changed 2) Number of slots: Not changed 3) Program Number of occupied I/O points: Not changed 4) Specifications Rated output voltage: Not changed Rated output current: Changed ON voltage/ON current: Changed OFF voltage/OFF current: Changed Input resistance: Changed 5) Functions: Changed (Interrupt processing condition can be set in 4-point unit.)	XY

Product	Related model for discontinuation	Transition to the AnS series		
	A series model	AnS series model	Restrictions	Applicable adapter
Interrupt module	AI61-S1	A1SI61	△ 1) External wiring: Changed 2) Number of slots: Not changed 3) Program Number of occupied I/O points: Changed (16 points occupied) 4) Specifications Rated output voltage: Not changed Rated output current: Changed ON voltage/ON current: Changed OFF voltage/OFF current: Changed Input resistance: Changed 5) Functions: Changed (Interrupt processing condition can be set in 4-point unit.) 6) Others: The response time is different.	XY
	140mA	57mA		
Analog input module	A616AD	None	× Using the A1S68AD is recommended. 1) External wiring: Changed (Terminal block is different.) 2) Number of slots: Changed (2 modules required) 3) Program: I/O signals and buffer memory address are changed. 4) Performance specifications change: 8CH/module, input signals (Only plus current can be input.) 5) Function specifications: Multiplexer function not available	Not used
	1000mA			
	A68AD	A1S68AD	△ 1) External wiring: Changed (Terminal block is different.) 2) Number of slots: Not changed 3) Program: I/O signals and buffer memory address are changed. 4) Performance specifications change: I/O characteristics 5) Function specifications: Setting method of the A/D conversion disable function has been changed 6) Since internal current consumption increases by combination with the A1ADP-SP, checking power capacity and receiving end voltage is required (Refer to POINT (1) to (3)).	SP
	390mA	400mA		

Product	Related model for discontinuation	Transition to the AnS series		
	A series model	AnS series model	Restrictions	Applicable adapter
Analog input module	A68AD-S2 390mA	A1S68AD 400mA	△ 1) External wiring: Changed (Terminal block is different.) 2) Number of slots: Not changed 3) Program: I/O signals and buffer memory address are changed. 4) Performance specifications change: I/O characteristics 5) Function specifications: Not changed 6) Since internal current consumption increases by combination with the A1ADP-SP, checking power capacity and receiving end voltage is required (Refer to POINT (1) to (3)).	SP
	A68ADN 400mA	A1S68AD 400mA	△ 1) External wiring: Changed (Terminal block is different.) 2) Number of slots: Not changed 3) Program: I/O signals and buffer memory address are changed. 4) Performance specifications change: I/O characteristics and resolution 5) Function specifications: Not changed	SP
Multi-plexer	A60MX 650mA	None	× Alternating with multiple A1S68AD modules is recommended.	Not used
	A60MXRN 350mA	None	× Using multiple A1S68ADs and perform isolation between channels is recommended.	Not used
	A60MXR 500mA	None	× Using multiple A1S68ADs and perform isolation between channels is recommended.	Not used
	A60MXTN 640mA	None	× Alternating with multiple A1S68TD modules is recommended.	Not used
	A60MXT 800mA	None	× Alternating with multiple A1S68TD modules is recommended.	Not used

Product	Related model for discontinuation	Transition to the AnS series			
	A series model	AnS series model		Restrictions	Applicable adapter
Analog output module	A616DAI 300mA	None	×	Using the A1S68DAI is recommended. 1) External wiring: Changed (Terminal block is different.) 2) Number of slots: Changed (2 modules required) 3) Program: I/O signals and buffer memory address are changed. 4) Performance specifications change: 8CH/module, input current range 5) Function specifications: The relation between the D/A conversion disable channel and the conversion time is changed.	Not used
	A616DAV 380mA	None	×	Using the A1S68DAV is recommended. 1) External wiring: Changed (Terminal block is different.) 2) Number of slots: Changed (2 modules required) 3) Program: I/O signals and buffer memory address are changed. 4) Performance specifications change: 8CH/module, resolution and accuracy 5) Function specifications: The relation between the D/A conversion disable channel and the conversion time is changed.	Not used
	A62DA 600mA	A1S62DA	△	1) External wiring: Changed (Terminal block is different.) 2) Number of slots: Not changed 3) Program: I/O signals and buffer memory address are changed. 4) Performance specifications change: I/O characteristics and conversion time 5) Function specifications: Not changed 6) Since internal current consumption increases by combination with the A1ADP-SP, checking power capacity and receiving end voltage is required (Refer to POINT (1) to (3)).	SP

Product	Related model for discontinuation	Transition to the AnS series		
	A series model	AnS series model	Restrictions	Applicable adapter
Analog output module	A62DA-S1	A1S62D A	△ 1) External wiring: Changed (Terminal block is different.) 2) Number of slots: Not changed 3) Program: I/O signals and buffer memory address are changed. 4) Performance specifications change: I/O characteristics and conversion time 5) Function specifications: Not changed 6) Since internal current consumption increases by combination with the A1ADP-SP, checking power capacity and receiving end voltage is required (Refer to POINT (1) to (3)).	SP
	600mA	800mA		
	A68DAI-S1	A1S68D AI	△ 1) External wiring: Changed (Terminal block is different.) 2) Number of slots: Not changed 3) Program: I/O signals and buffer memory address are changed. 4) Performance specifications change: Output current range, I/O characteristics, and increased current consumption 5) Function specifications: Not changed 6) Since internal current consumption increases by combination with the A1ADP-SP, checking power capacity and receiving end voltage is required (Refer to POINT (1) to (3)).	SP
	150mA	850mA		
	A68DAV	A1S68D AV	△ 1) External wiring: Changed (Terminal block is different.) 2) Number of slots: Not changed 3) Program: I/O signals and buffer memory address are changed. 4) Performance specifications change: Output current range, I/O characteristics, and increased current consumption 5) Function specifications: Not changed 6) Since internal current consumption increases by combination with the A1ADP-SP, checking power capacity and receiving end voltage is required (Refer to POINT (1) to (3)).	SP
	150mA	650mA		

Product	Related model for discontinuation	Transition to the AnS series			
	A series model	AnS series model		Restrictions	Applicable adapter
Temperature input module	A616TD	None	×	Using the A1S68TD is recommended. 1) External wiring: Changed (Terminal block is different.) 2) Number of slots: Changed (2 modules required) 3) Program: I/O signals and buffer memory address are changed. 4) Performance specifications change: 8CH/module, input temperature range, and conversion accuracy 5) Function specifications: The relation between the conversion disable channel and the conversion time is changed.	Not used
	1000mA				
	A68RD3N	None	×	Using the A1S62RD3N is recommended. 1) External wiring: Changed (Terminal block is different.) 2) Number of slots: Changed (4 modules required) 3) Program: Changed 4) Performance specifications change: 2CH/module 5) Function specifications: Not changed	Not used
	940mA				
	A68RD4N	None	×	Using the A1S62RD4N is recommended. 1) External wiring: Changed (Terminal block is different.) 2) Number of slots: Changed (4 modules required) 3) Program: Changed 4) Performance specifications change: 2CH/module 5) Function specifications: Not changed	Not used
	410mA				
High-speed counter module	AD61	A1SD62	△	1) External wiring: Changed (Terminal block is different.) 2) Number of slots: Not changed 3) Program: Buffer memory address is changed. 4) Performance specifications change: Upward-compatibility 5) Function specifications: Upward-compatibility	SP
	300mA	100mA			

Product	Related model for discontinuation	Transition to the AnS series			
	A series model	AnS series model		Restrictions	Applicable adapter
High-speed counter module	AD61-S1	A1SD62	△	1) External wiring: Changed (Terminal block is different.) 2) Number of slots: Not changed 3) Program: Buffer memory address is changed. 4) Performance specifications change: Upward-compatibility 5) Function specifications: Upward-compatibility	SP
	300mA	100mA			
Positioning module	AD70	A1SD70	× *1	1) External wiring: Changed (Terminal block is different.) 2) Number of slots: 1 slot 2 slots 3) Program: Not changed 4) Performance specifications change:Not changed 5) Function specifications: Not changed	Not used
	300mA	300mA			
	AD72 900mA	None	×	No alternative model	Not used
	AD75M1	A1SD75 M1	○	No restrictions The A1SD75-C01HA cable is required since the peripheral device connection connector is different.	SP
	700mA	700mA			
	AD75M2	A1SD75 M2	○	No restrictions The A1SD75-C01HA cable is required since the peripheral device connection connector is different.	SP
	700mA	700mA			
	AD75M3	A1SD75 M3	○	No restrictions The A1SD75-C01HA cable is required since the peripheral device connection connector is different.	SP
	700mA	700mA			
AD75P1-S3	A1SD75 P1-S3	○	No restrictions The A1SD75-C01HA cable is required since the peripheral device connection connector is different.	SP	
700mA	700mA				
AD75P2-S3	A1SD75 P2-S3	○	No restrictions The A1SD75-C01HA cable is required since the peripheral device connection connector is different.	SP	
700mA	700mA				
AD75P3-S3	A1SD75 P3-S3	○	No restrictions The A1SD75-C01HA cable is required since the peripheral device connection connector is different.	SP	
700mA	700mA				

*1: As for specification, △

Product	Related model for discontinuation	Transition to the AnS series			
	A series model	AnS series model		Restrictions	Applicable adapter
Position detection module	A61LS 800mA	None	×	No alternative model	Not used
	A62LS-S5 1500mA	None	×	No alternative model	Not used
	A63LS 1350mA	None	×	No alternative model	Not used
Intelligent communication	AD51H-S3 1000mA	A1SD51 S 400mA	△	The A1SD51S is different from the AD51H-S3 in the following specifications. AD51H-S3→A1SD51S 1) Number of tasks: 8→2 2) Memory: 300→60kbytes 3) Parallel: Available→None 4) RS-232 connector: 25-pin→9-pin 5) Number of slots: 2→1 (One slot will be an empty slot.) 6) Memory card I/F: 2→0 (File creation is disabled.) 7) LED display not provided 8) Program record medium: Memory card, EPROM→built-in EEPROM	SP
	AD51-S3 1300mA	A1SD51 S 400mA	△	Replace the BASIC program with a program for A1SD51S	SP
Ethernet module	AJ71E71N-B2 670mA	A1SJ71 E71N- B2 660mA	○	No restrictions	SP
	AJ71E71N-B5 550mA	A1SJ71 E71N- B5 570mA	○	Since internal current consumption increases by combination with the A1ADP-SP, checking power capacity and receiving end voltage is required (Refer to POINT (1) to (3)).	SP
	AJ71E71N-T 400mA	A1SJ71 E71N3- T 690mA	○	Since internal current consumption increases by combination with the A1ADP-SP, checking power capacity and receiving end voltage is required (Refer to POINT (1) to (3)).	SP
	AJ71E71N3-T 690mA	A1SJ71 E71N3- T 690mA	○	No restrictions	SP

Product	Related model for discontinuation	Transition to the AnS series			
	A series model	AnS series model		Restrictions	Applicable adapter
MELSEC NET/B data link module	AJ71AT21B	A1SJ71 AT21B	○	No restrictions	SP
	720mA	660mA			
MELSEC NET data link module	AJ71AP21	A1SJ71 AP21	○	No restrictions	SP
	500mA	330mA			
	AJ71AR21	A1SJ71 AR21	○	No restrictions	SP
	900mA	800mA			
MELSEC NET/10 network module	AJ71LP21	A1SJ71 LP21	○	No restrictions	SP
	650mA	650mA			
	AJ71BR11	A1SJ71 BR11	○	No restrictions	SP
	800mA	800mA			
	AJ71LR21	A1SJ71 LR21	○	No restrictions	SP
	1200mA	1140mA			
CC-Link master/local module	AJ61BT11	A1SJ61 BT11	○	No restrictions	SP
	450mA	400mA			
MELSEC NET/MINI-S3 master module	AJ71PT32-S3	A1SJ71 PT32-S3	△	Monitor station function not available	SP
	350mA	350mA			
	AJ71T32-S3	A1SJ71 PT32-S3	△	1) Monitor station function not available 2) Since internal current consumption increases by combination with the A1ADP-SP, checking power capacity and receiving end voltage is required (Refer to POINT (1) to (3)).	SP
	300mA	350mA			
	AJ71T32-S4	None	×	Changing the system from MELSECNET/MINI-S3 to CC-Link is recommended.	Not used
	300mA				
MELSEC-I/OLINK master module	AJ51T64	A1SJ51 T64	○	No restrictions	SP
	115mA	115mA			

Product	Related model for discontinuation	Transition to the AnS series			
	A series model	AnS series model		Restrictions	Applicable adapter
JEMANET (OPCN-1) interface module	AJ71J92-S3	A1SJ71 J92-S3	○	No restrictions	SP
	500mA	400mA			
B/NET interface module	AJ71B62-S3	A1SJ71 B62-S3	○	No restrictions	SP
	170mA	80mA			
Terminal interface module	AJ71C21-S1	None	×	No alternative model	Not used
Multidrop link module	AJ71C22-S1	A1SJ71 UC24-R4	△	The following functions are different. 1) Buffer memory Work area: 61h to 07FF→71h to 0DFFh 2) LED For slave station I/O monitor display: Available→None 3) Setting switch Baud rate setting: Fixed to 38400bps→Settable to 19200/38400 Master/local: Fixed to master→Settable 4) Terminal block screw M4→M3.5 5) Terminal resistor Built-in→externally connected	SP
	1400mA	100mA			
Host controller high-speed link	AJ71C23-S3	None	×	No alternative model	Not used
Computer link module	AJ71UC24	A1SJ71 UC24-PRF ^{*1} 100mA A1SJ71 UC24-R2 ^{*1} 100mA A1SJ71 UC24-R4 ^{*1} 100mA	△	1) Either the RS-232 connector or RS-422/485 terminal block A1SJ71UC24-PRF/R2/R4 is available. 2) For the A1SJ71UC24-PRF/R2/R4, the linked operation function between the RS-232 and RS-422 is not available. 3) Number of RS-232 connector pins 25-pin→9-pin	SP
	300mA				
	AJ71C24-S1	None	×	No alternative model	Not used
	1400mA				

Product	Related model for discontinuation	Transition to the AnS series			
	A series model	AnS series model		Restrictions	Applicable adapter
Computer link module	AJ71C24-S7 1400mA	None	×	No alternative model	Not used
MODBUS module	AJ71UC24-S2 1400mA	A1SJ71 UC24-R2-S2 100mA A1SJ71 UC24-R4-S2 100mA	△	Either RS-232 or RS-422/485 interface is available. For AnS series, the linked operation between the RS-232 and RS-422 is not available. RS-232 connector: 25-pin→9-pin	SP
Profibus-DP interface module	AJ71PB92D 540mA	A1SJ71 PB92D 560mA	○	Since internal current consumption increases by combination with the A1ADP-SP, checking power capacity and receiving end voltage is required (Refer to POINT (1) to (3)).	SP
		A1SJ71 PB93D 360mA	○	No restrictions	SP
Profibus-FMS Interface module	AJ71PB96F 540mA	A1SJ71 PB96F 560mA	○	Since internal current consumption increases by combination with the A1ADP-SP, checking power capacity and receiving end voltage is required (Refer to POINT (1) to (3)).	SP
Device Net master module	AJ71DN91 240mA	A1SJ71 DN91 240mA	○	No restrictions	SP
Supersonic linear scale module	A64BTL 1050mA	None	×	No alternative model	Not used
External error check module	AD51FD-S3 1000mA	None	×	No alternative model	Not used
PC fault detection module	AS91 80mA	A1SS91 80mA	○	No restrictions	SP

Product	Related model for discontinuation	Transition to the AnS series			
	A series model	AnS series model	Restrictions	Applicable adapter	
Vision sensor module	AS25VS 2620mA	None	×	Connecting a commercially available vision sensor and programmable controller with RS232, Ethernet or Digital I/O for data loading is recommended.	Not used
	AS50VS 3300mA	None	×	Connecting a commercially available vision sensor and programmable controller with RS232, Ethernet or Digital I/O for data loading is recommended.	Not used

- *1 When the AnACPU communicates in nonprocedural mode using the dedicated instructions (PR/PRN/INPUT), turn on the transmission specification setting switch (SW03) on the module of software version X or later.

If the software version of the module is W or earlier, use the FROM/TO instructions for communication.

There are no restrictions when the AnACPU communicates in nonprocedural mode using the FROM/TO instructions or the used CPU module is except the AnACPU.

8.3 List of Transition from the QnA Series to AnS Series

Product	Related model for discontinuation	Transition to the AnS series			
	QnA series model	AnS series model		Restrictions	Applicable adapter
Ethernet module	AJ71QE71N-B2 560mA	A1SJ71QE71N-B2 530mA	○	No restrictions	SP
	AJ71QE71N-B5 400mA	A1SJ71QE71N-B5 400mA	○	No restrictions	SP
	AJ71QE71N-T 400mA	A1SJ71QE71N-3-T 530mA	○	Since internal current consumption increases by combination with the A1ADP-SP, checking power capacity and receiving end voltage is required (Refer to POINT (1) to (3)).	SP
	AJ71QE71N3-T 530mA	A1SJ71QE71N-3-T 530mA	○	No restrictions	SP
Serial communication module	AJ71QC24N 400mA	A1SJ71QC24N 350mA	△	RS-232 connector: 25-pin→9-pin	SP
	AJ71QC24N-R2 300mA	A1SJ71QC24N-R2 300mA	△	RS-232 connector: 25-pin→9-pin	SP
	AJ71QC24N-R4 600mA	A1SJ71QC24N 350mA	△	For Q2AS series, use A1SJ71QC24N and connect the RS232-422 converter to 1ch.	SP
CC-Link master/local module	AJ61QBT11 450mA	A1SJ61QBT11 100mA	○	No restrictions	SP
MELSEC NET/10 network module	AJ71QLP21 650mA	A1SJ71QLP21 400mA	○	No restrictions	SP
	AJ71QBR11 800mA	A1SJ71QBR11 800mA	○	No restrictions	SP
	AJ71QLR21 1140mA	A1SJ71QLR21 1140mA	○	No restrictions	SP

8.4 List of Transition from the Q4AR Series to AnS Series

Product	Related model for discontinuation	Transition to the AnS series		
	Q4AR series model	AnS series model	Restrictions	Applicable adapter
Ethernet module	AJ71QE71N-B2 560mA	A1SJ71QE71N-B2 530mA	○ No restrictions	SP
	AJ71QE71N-B5 400mA	A1SJ71QE71N-B5 400mA	○ No restrictions	SP
	AJ71QE71N-T 400mA	A1SJ71QE71N-3-T 530mA	○ Since internal current consumption increases by combination with the A1ADP-SP, checking power capacity and receiving end voltage is required (Refer to POINT (1) to (3)).	SP
	AJ71QE71N3-T 530mA	A1SJ71QE71N-3-T 530mA	○ No restrictions	SP
Serial communication module	AJ71QC24N 400mA	A1SJ71QC24N 350mA	△ RS-232 connector: 25-pin→9-pin	SP
	AJ71QC24N-R2 300mA	A1SJ71QC24N-R2 300mA	△ RS-232 connector: 25-pin→9-pin	SP
	AJ71QC24N-R4 600mA	A1SJ71QC24N 350mA	△ For Q2AS series, use A1SJ71QC24N and connect the RS232-422 converter to 1ch.	SP
MELSEC NET/10 network module	AJ71QLP21 650mA	A1SJ71QLP21 400mA	○ No restrictions	SP
	AJ71QBR11 800mA	A1SJ71QBR11 800mA	○ No restrictions	SP
	AJ71QLR21 1140mA	A1SJ71QLR21 1140mA	○ No restrictions	SP

WARRANTY

Mitsubishi will not be held liable for damage caused by factors found not to be the cause of Mitsubishi; machine damage or lost profits caused by faults in the Mitsubishi products; damage, secondary damage, accident compensation caused by special factors unpredictable by Mitsubishi; damages to products other than Mitsubishi products; and to other duties.

Country/Region	Sales office/Tel	Country/Region	Sales office/Tel
USA	Mitsubishi Electric Automation Inc. 500 Corporate Woods Parkway, Vernon Hills, IL 60061, USA Tel : +1-847-478-2100	South Africa	CBI-Electric. Private Bag 2016, ZA-1600 Isando, South Africa Tel : +27-11-977-0770
Brazil	MELCO-TEC Representacao Comercial e Assessoria Tecnica Ltda. Av. Paulista, 1439, cj74, Bela Vista, Sao Paulo CEP: 01311-200-SP Brazil Tel : +55-11-3146-2200	China	Mitsubishi Electric Automation (China) Ltd. No.1386 Hongqiao Road, Mitsubishi Electric Automation Center, Changning District, Shanghai, China Tel : +86-21-2322-3030
Germany	Mitsubishi Electric Europe B.V. German Branch Gothaer Strasse 8, D-40880 Ratingen, Germany Tel : +49-2102-486-0	Taiwan	Setuyo Enterprise Co., Ltd. 6F., No.105, Wugong 3rd Road, Wugu District, New Taipei City 24889, Taiwan, R.O.C. Tel : +886-2-2299-2499
UK	Mitsubishi Electric Europe B.V. UK Branch Travellers Lane, Hatfield, Hertfordshire, AL10 8XB, UK. Tel : +44-1707-27-6100	Korea	Mitsubishi Electric Automation Korea Co., Ltd. 3F, 1480-6, Gayang-Dong, Gangseo-Gu, Seoul, 157-200, Korea Tel : +82-2-3660-9530
Italy	Mitsubishi Electric Europe B.V. Italian Branch Viale Colleoni 7-20864 Agrate Brianza (Milano), Italy Tel : +39-039-60531	Singapore	Mitsubishi Electric Asia Pte, Ltd. Industrial Division 307, Alexandra Road, Mitsubishi Electric Building, Singapore, 159943 Tel : +65-6470-2308
Spain	Mitsubishi Electric Europe B.V. Spanish Branch Carretera de Rubi 76-80.AC.420, E-08190 Sant Cugat del Valles (Barcelona), Spain Tel : +34-93-565-3131	Thailand	Mitsubishi Electric Automation (Thailand) Co., Ltd. Bang-Chan Industrial Estate No.111 Soi Serithai 54, T.Kannayao, A.Kannayao, Bangkok 10230 Thailand Tel : +66-2906-3238
France	Mitsubishi Electric Europe B.V. French Branch 25, Boulevard des Bouvets, F-92741 Nanterre Cedex, France Tel : +33-1-5568-5568	Indonesia	P. T. Autoteknindo Sumber Makmur Muara Karang Selatan, Block A / Utara No.1 Kav. No. 11, Kawasan Industri Pergudangan, Jakarta-Utara 14440, P.O. Box 5045, Indonesia Tel : +62-21-663-0833
Czech Republic	Mitsubishi Electric Europe B.V.-o.s.Czech office Avenir Business Park, Radicka 751/113e, 158 00 Praha5, Czech Republic Tel : +420-251-551-470	India	Mitsubishi Electric India Pvt. Ltd. 2nd Floor, Tower A & B, Cyber Greens, DLF Cyber City, DLF Phase-III, Gurgaon-122002 Haryana, India Tel : +91-124-463-0300
Poland	Mitsubishi Electric Europe B.V. Polish Branch ul. Krakowska 50, 32-083 Balice, Poland Tel : +48-12-630-47-00	Australia	Mitsubishi Electric Australia Pty. Ltd. 348 Victoria Road PO BOX11, Rydalmere, N.S.W 2116, Australia Tel : +61-2-9684-7777
Russia	Mitsubishi Electric Europe B.V. Russian Branch St.Petersburg office Piskarevsky pr. 2, bld 2, lit "Sch", BC "Benua", office 720; 195027, St. Petersburg, Russia Tel : +7-812-633-3497		



HEAD OFFICE : TOKYO BUILDING, 2-7-3 MARUNOUCHI, CHIYODA-KU, TOKYO 100-8310, JAPAN
NAGOYA WORKS : 1-14, YADA-MINAMI 5-CHOME, HIGASHI-KU, NAGOYA, JAPAN

When exported from Japan, this manual does not require application to the Ministry of Economy, Trade and Industry for service transaction permission.

Specifications subject to change without notice.